

PD2.5

PROJECTOR DROP MECHANISM

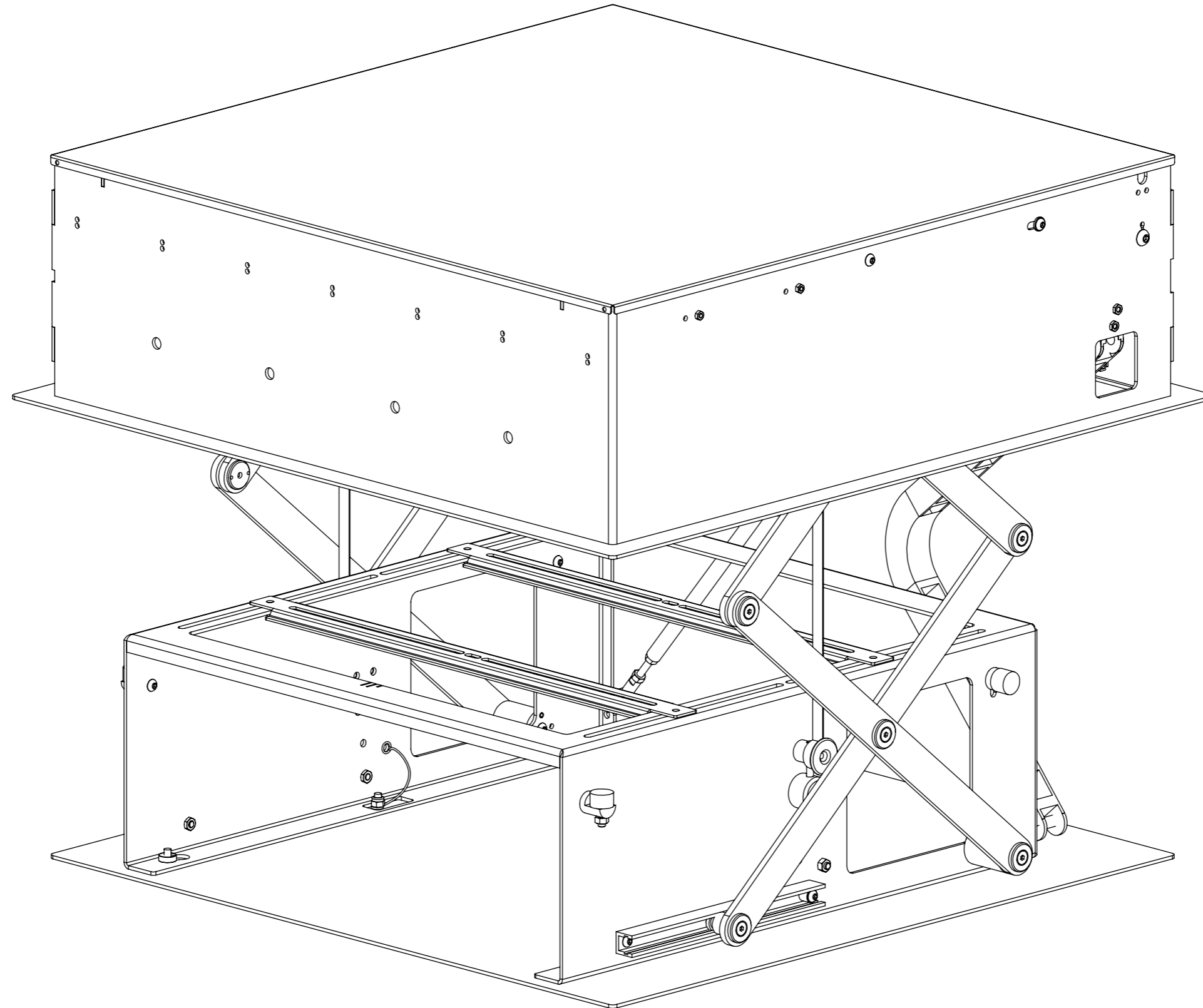

future automation



PD2.5

PROJECTOR DROP MECHANISM



SPECIFICATION	MEASUREMENTS
Product Dimensions	720mm (28 3/8") W x 720mm (28 3/8") D x 217mm (8 9/16") H
Maximum Projector Size	505mm (19 7/8") W x 560mm (22 1/16") D x 195mm (7 11/16") H
Maximum Weight Capacity	15Kg (33lb)
Maximum Speed	50mm/s
Travel From Ceiling	400mm (15 3/4") - Standard 700mm (27 1/2") - Available 940mm (37") - Available
Depth Within Ceiling	211mm(8 5/16")
Product Weight	25kg(55lb)
Packaging Dimensions	950mm (37 3/8") W x 950mm (37 3/8") D x 350mm (13 3/4") H
Shipping Weight	32Kg (70lb)
Maximum Tilt	10°
Movement Type	Motorised
Power Supply Required	110V - 240V AC
Power Consumption Max.	110W
Control Options	IR Remote, RS232, Contact Closure
Product Options / Features	Specific Projector mounts / adapters, Custom RAL paint finishes, Marine suitable version, Custom size Varients
Package Contents	Mechanism, IR remote control
Marine Suitable	No

PD2.5

PROJECTOR DROP MECHANISM

DESIGN HIGHLIGHTS

Quick and simple mechanism installation.

Available with three different drop options. Standard drop is 400mm (15 3/4"), Long drop is 700mm (27 1/2") and Extra Long drop is 940mm (37").

Projector carriage can be tilted up to 10° once dropped.

Full cable management keeps all power and signal cables as neat and tidy as possible.

Top cover panel finishes internal void in matching white satin finish.

Slotted mounting system provides easily adjustable installation for almost any projector.

Standard control box can also control a third party product such as a projector screen.

VIEWS BELOW SHOW ACTION FROM IN POSITION TO DOWN POSITION

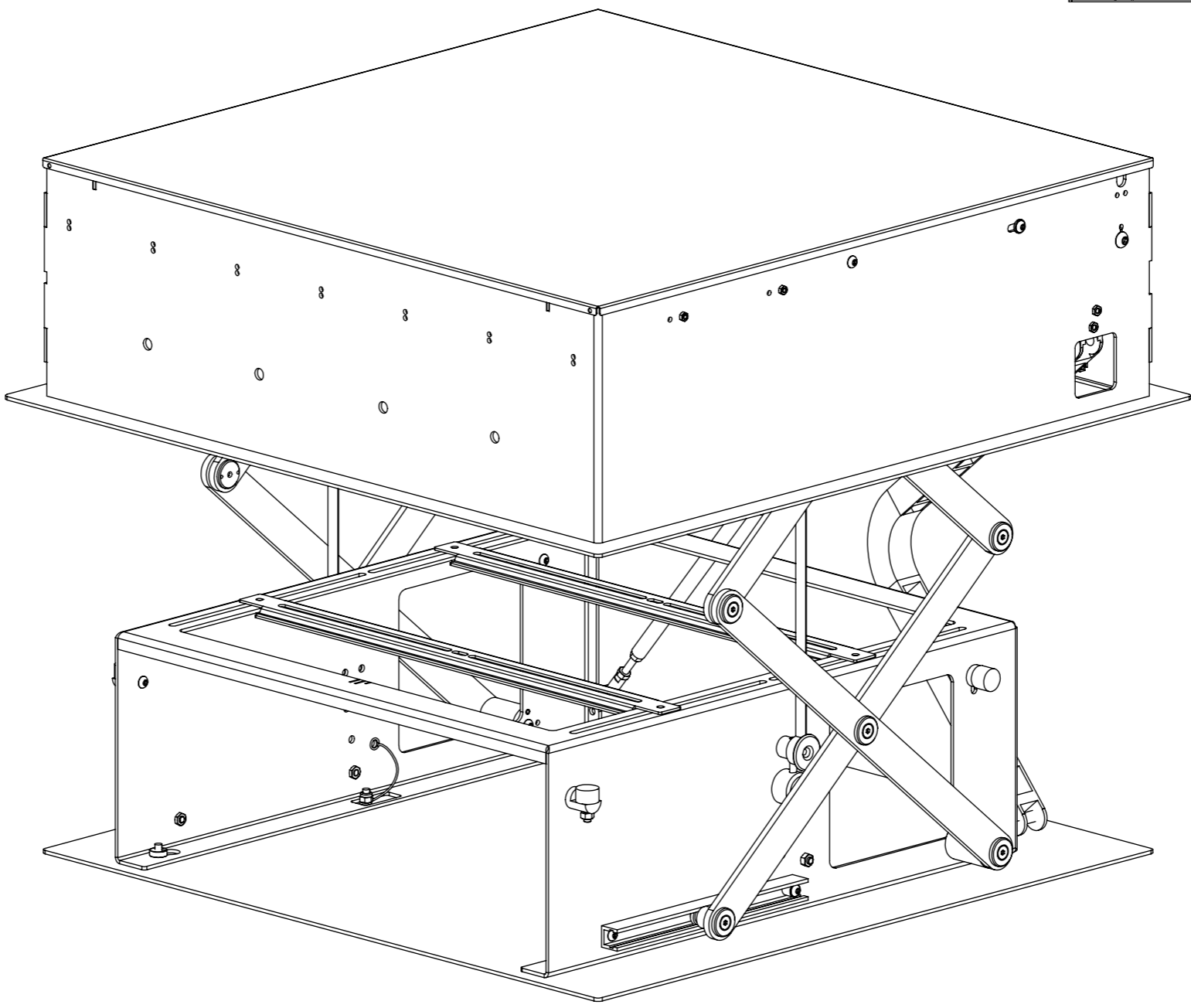
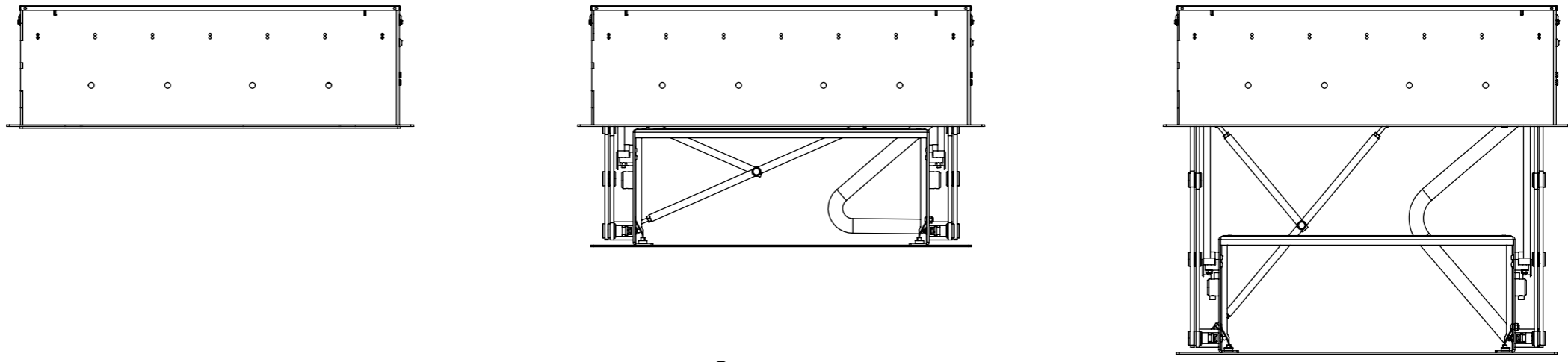

PD2.5 PROJECTOR DROP MECHANISM

CEILING DETAILS

Below shows the PD2.5 installed in a ceiling. The top cover panel is not shown to aid clarity.

The projector drop mechanism is inserted like a ceiling speaker. A lip around the underside of the mechanism neatly covers the cut edge of the plaster.

PD2.5 mechanism requires a ceiling cut out size 680mm x 680mm [26 3/4" x 26 3/4"].

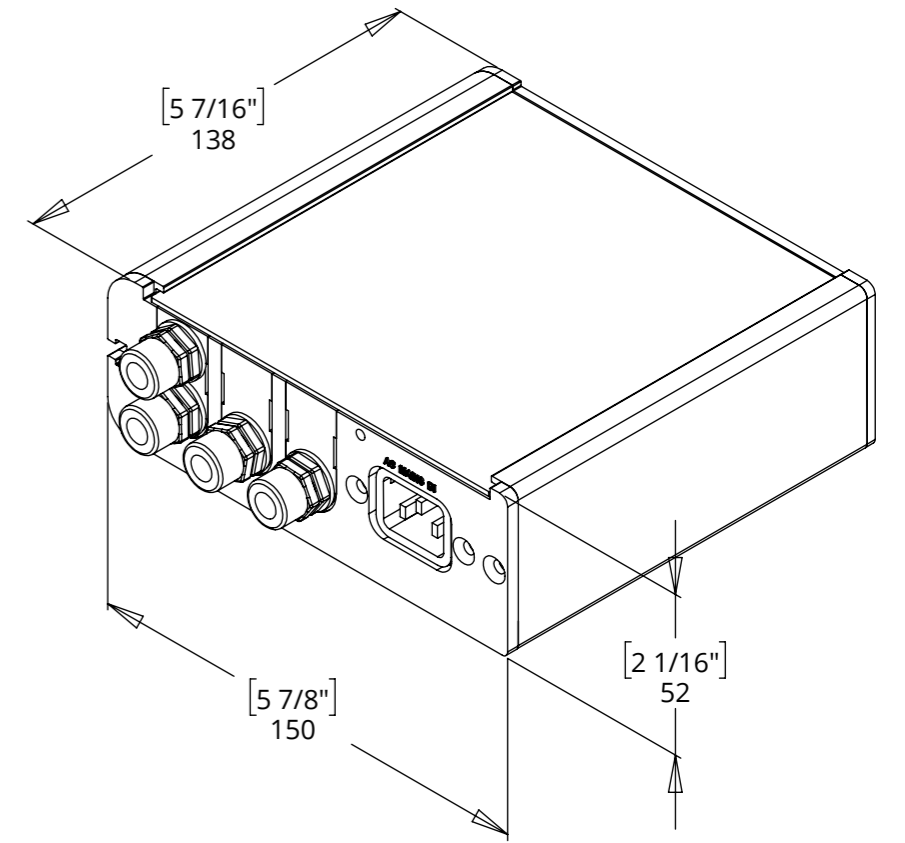
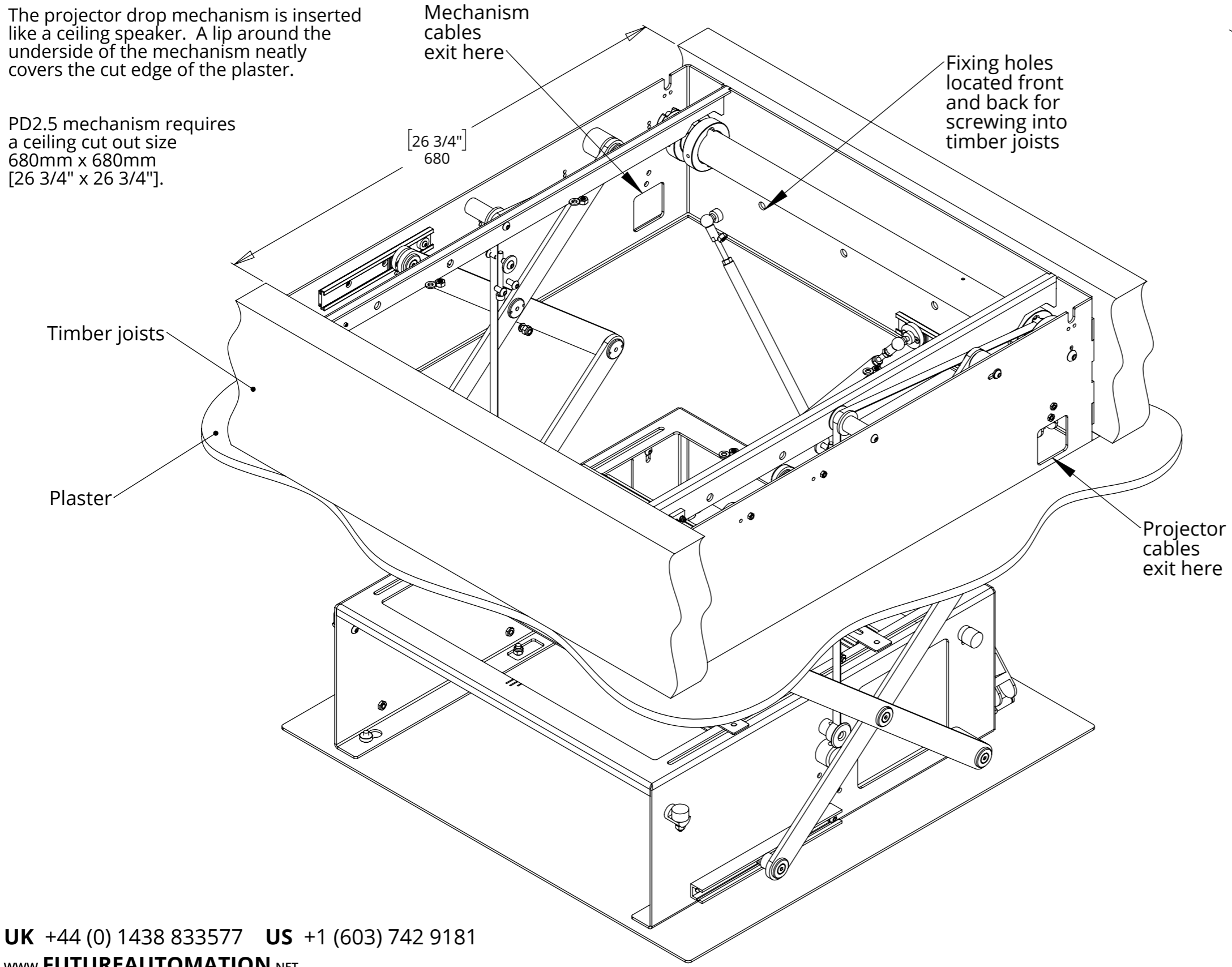

Control Box

The size of the mechanism control box is shown above. This must be located in an easily accessible location.

In the cases where the mechanism cables need to be extended, a four core mains cable and a three core low voltage cable need to be run from the mechanism to the control box.

The control box can also be used to control an electric projector screen (standard four core mains type).

PD2.5



PROJECTOR DROP MECHANISM

PROJECTOR TILT

By undoing and repositioning one bolt on each side, a significant tilt angle can be achieved.

This is useful when using the projector drop in rooms with high ceilings where the projector is a lot higher than the screen being viewed.

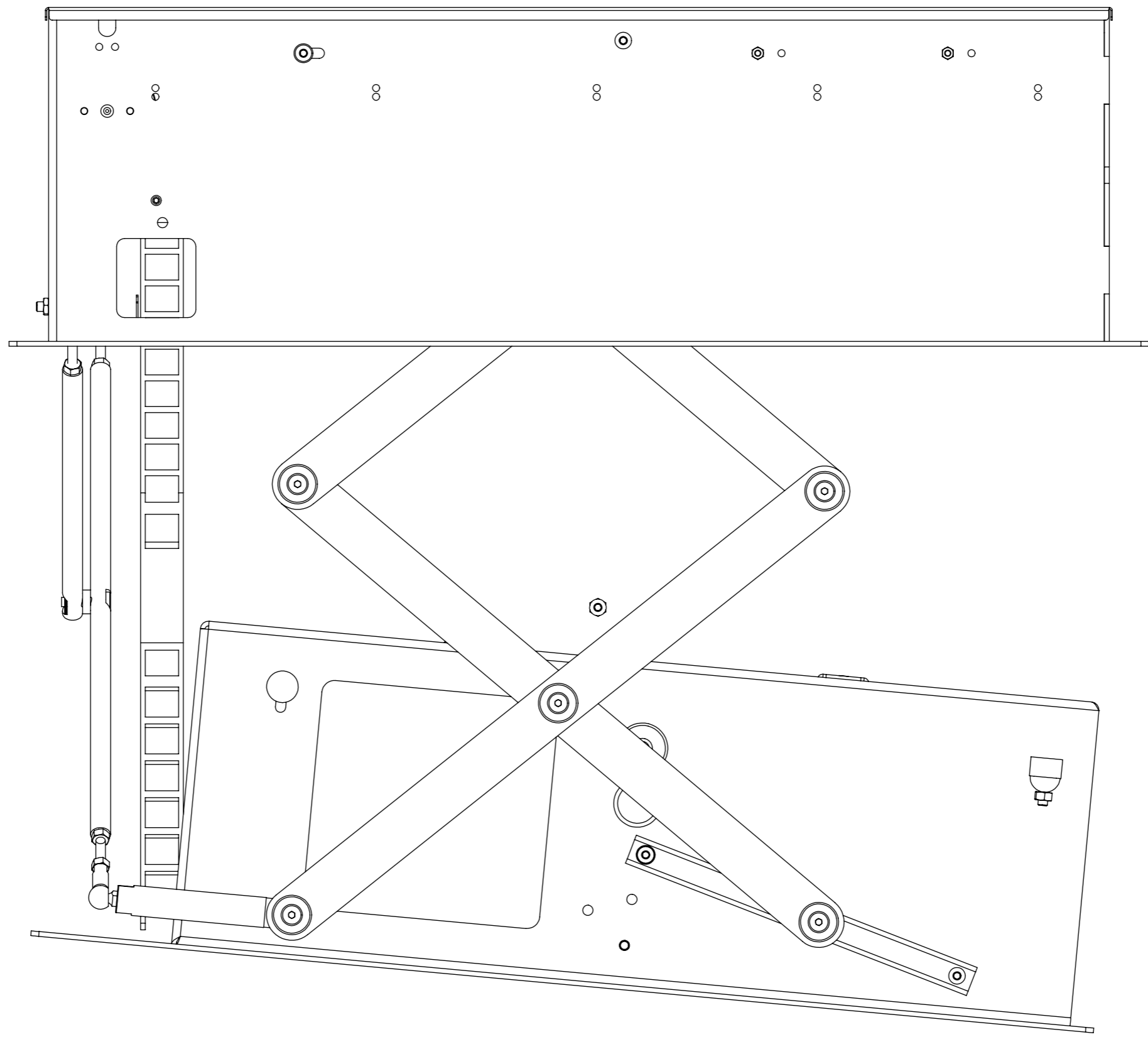

KEYSTONE

Using the tilt adjustment means the projector image must be altered using the keystone function on the projector.

PD2.5 PROJECTOR DROP MECHANISM

FIXED BOTTOM PANEL FIXING

Bottom panel comes secured to the mechanism by Nyloc nuts.

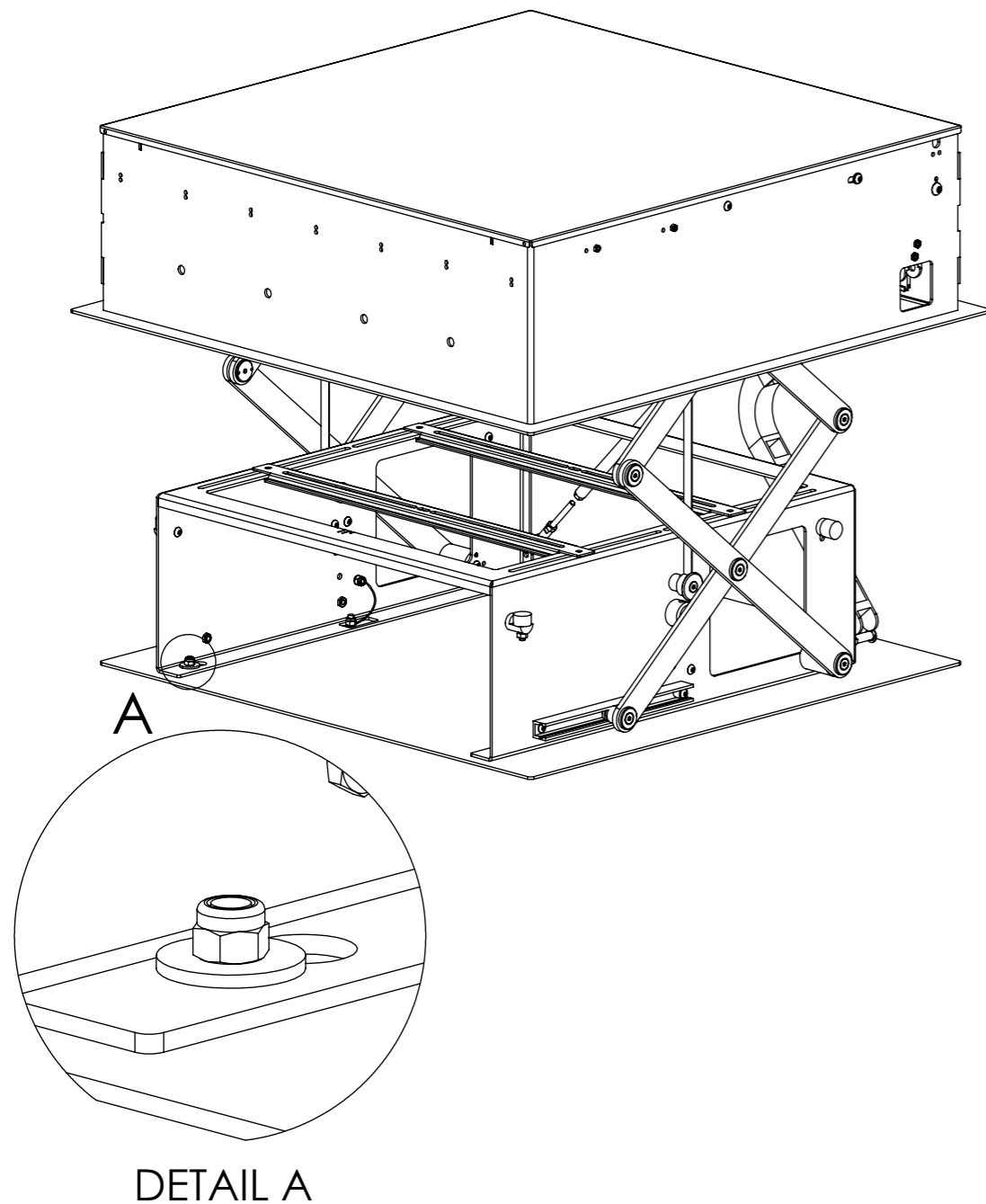

SERVICABLE BOTTOM PANEL FIXING

Optional bottom panel retainers are included to allow the bottom panel to be removable.

If these retainers are used the installer must ensure that the fall arrest cable is secured to both the projector carriage and the bottom panel (DETAIL C).

To remove bottom panel, slide back by 15mm and the panel should drop away from the carriage.

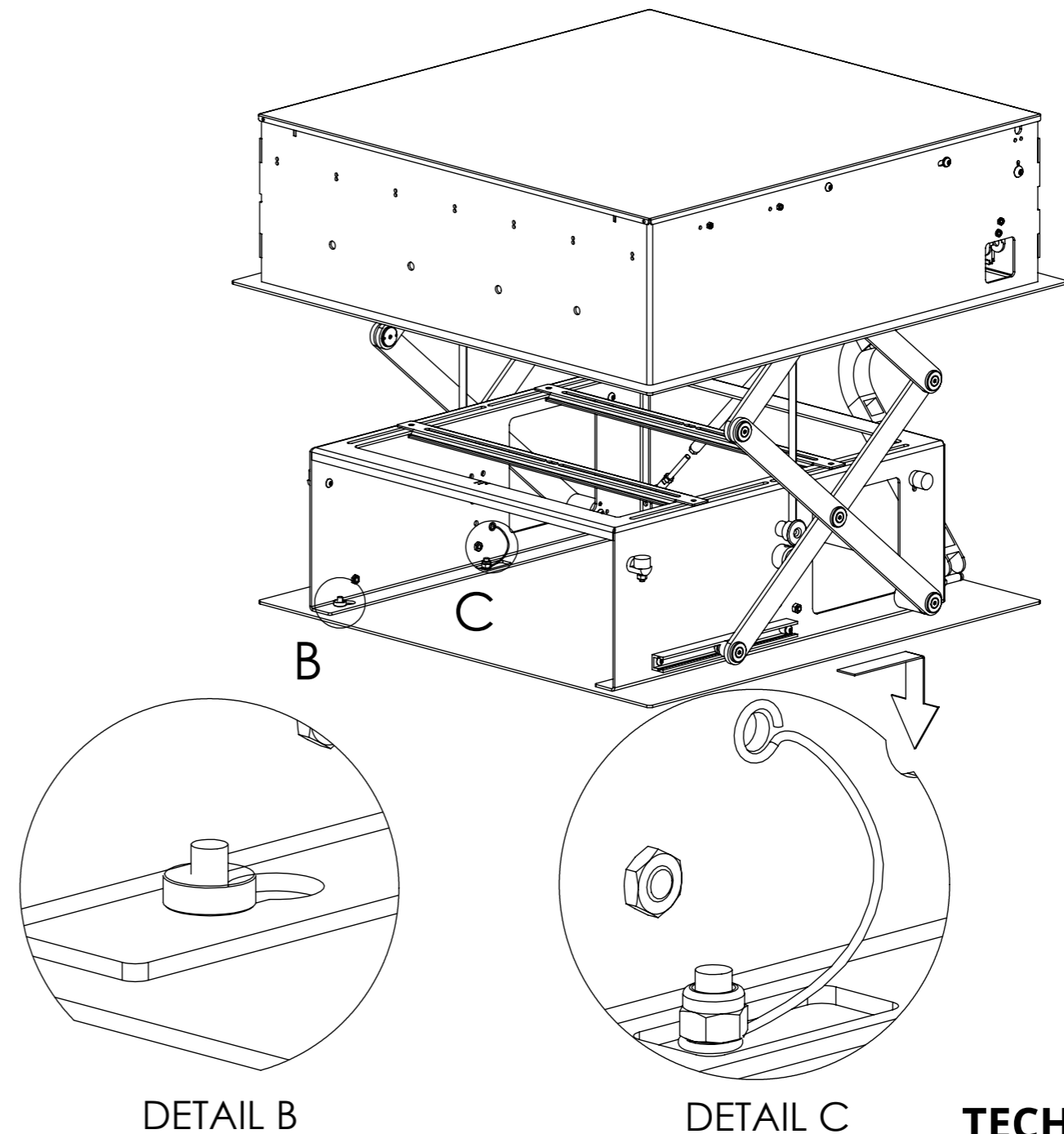

PD2.5 PROJECTOR DROP MECHANISM

GENERAL DIMENSIONS

