

Ultra-compact, full range, two way passive cabinet for background sound reinforcement. It consists of a 5" transducer and a 1" high frequency neodymium tweeter.



Key features

- Ultra-compact light weight
- Background sound reinforcement
- ARK processor optimised preset
- White & black colour optional
- Rugged design

Applications

- Club & bar installations
- Live sound
- Theatres
- Houses of worship
- Broadcast
- Public address
- Multi media spaces

General description & specifications

The QB-5 is a two-way versatile, ultracompact light weight, passive cabinet offering high-performance for background sound applications.

It features a 5" low/mid transducer with rubber surround and a 1" neodymium tweeter with micro foil diaphragm.

It is made from 9 mm premium birch plywood and coated with water based paint.

For low-frequency reinforcement we recommend the QB-5 be combined with the SUB-08.



Technical Data

Components	
• LF	1 x 5" transducer
• HF	1 x 1" tweeter
Frequency range	65 Hz - 20 KHz (-10dB)
Frequency response	75 Hz - 18 KHz (± 3dB)
Sensitivity	88 dB (1w @ 1m)
Max SPL	107 dB - 113 dB peak
Coverage angle	90° H x 90° V conic
Rated power RMS	80 W
Program power	160 W
Crossover	4700 Hz
Nominal impedance	16 Ω
Connectors	4 x Terminal Block 7.62 mm between pins
Finish	Water based paint
Material	9 mm premium birch plywood
Dimensions	254 x 167 x 186 mm (H x W x D)
Weight	3 Kg (6.6 lbs)

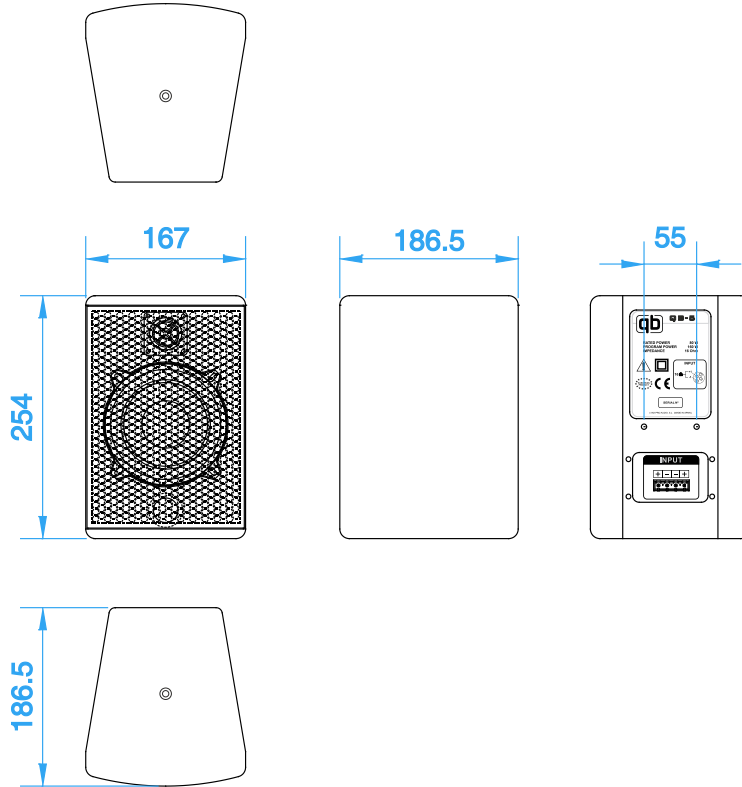
Dimensional Drawing



Accessories

	WB-10	Wall bracket for QB-5
	UBR-QB5	U bracket for QB-5

Impedance Response & Frequency Response

