

Coaxial two-way full range 6-inch ceiling mount loudspeaker system.



### Key features

- Two-way 6" coaxial speaker
- Coaxial loudspeaker with HF compression drivers
- Designed for voice and background music
- 40W AES @ 8Ω
- Low-impedance and high-impedance
- Power selector: 30/15/7.5/3.5 W 100v (1.9W @ 70V) 8Ω
- Easy install

### Applications

- Corporate training rooms, ballrooms
- Convention centers, exhibit halls, Houses of worship
- Malls, airports, nightclubs, bars and restaurants
- Auditorium, museums

### General description & specifications

The CS-6T is an in-ceiling loudspeaker with a great sound performance. It features a 6" woofer + 0.5" tweeter.

The CS-6T utilizes a 100V / 70V Line transformer that offers a selection of 30/15/7.5/3.5W ( 1.9W @ 70V) delivered to the loudspeaker system using or high impedance lines, or 8Ω bypass.

The baffle, bezel and rear enclosure are constructed from ABS. The rear enclosure adds damping material, providing an optimum internal volume for extended low-frequency performance.

### Technical Data

Components	6" 165 mm polypropylene cone 0.5" polypropylene Tweeter coaxially mounted
Frequency range	80 - 18.000 Hz
Rated power	40W (8 Ω) 160W Peak
Transformer taps	100V 30 / 15 / 7.5 / 3.75W 70V 30 / 15 / 7.5 / 3.75 / 1.9W Low Impedance 8 Ω
Max SPL	8 Ω 105 dB 100V / 70V 104dB
Sensitivity	89dB 1W / 1m @ Zn
Nominal impedance	8 Ω
Nominal coverage	90° conical dispersion
Recommended Signal Processing	90 Hz, at 24 dB per octave high pass filter
Crossover frequency	2500 Hz
Enclosure material	ABS
Grille	Powder coated steel, white finish, paintable
Colour	White
Dimensions H x Diameter	139 mm x 239 mm (5.5 in x 9.4 in)
Cut out size	205 mm (8.1 in)
Net weight	2 Kg (4.4 lbs)

## Dimensional Drawing

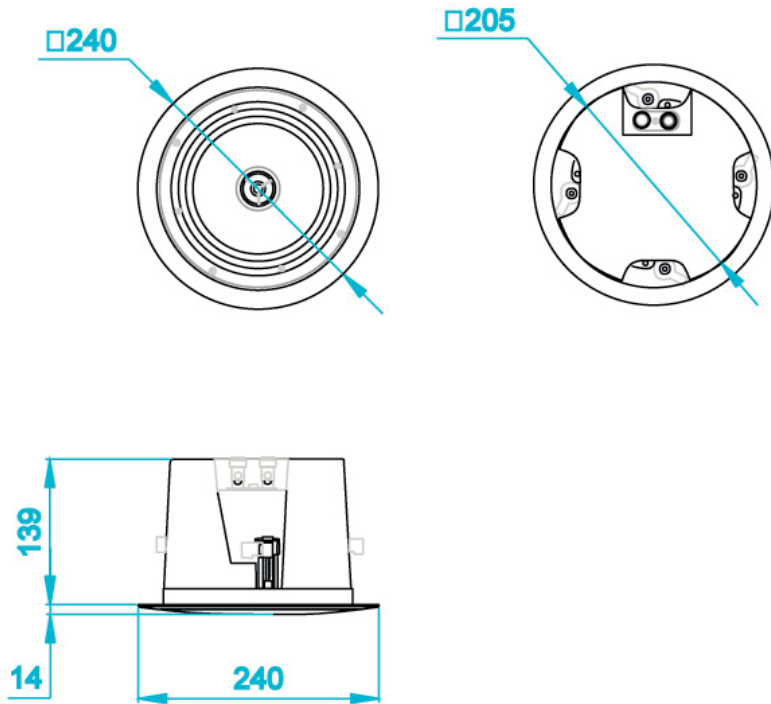

Dimensions in millimeters.

## Frequency response

1/6 Octave Smoothing, 1w@1m, anechoic chamber, half space.

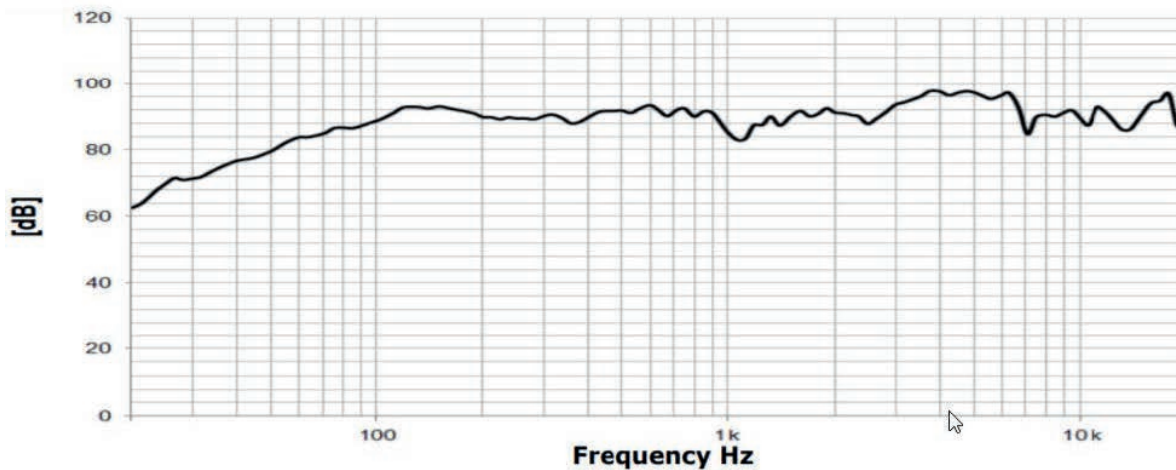

## Architectural specifications

The loudspeaker system shall be a 2 way, full-range ceiling loudspeaker system with a 6" low frequency transducer with a coaxially mounted 0.5" exit high frequency dome tweeter.

The loudspeaker baffle shall be constructed in ABS material in a white finish and ABS back can with a terminals connection integrate. The system shall have an frequency response of 80 Hz to 18 kHz (-10dB) and a nominal low impedance of 8 Ω. The sensitivity shall be 89 dB SPL at 1 meter on axis with one watt of pink noise. The loudspeaker system shall have a conical coverage pattern of 90°. The nominal system impedance shall be 8 ohms.

The system shall be equipped with a 30W line transformer use in 70V or 100V, with 30W, 15W, 7.5W, 3.75W and 1.9W taps available in 70V distributed systems and 30W, 15W, 7.5W and 3.75W taps available in 100V distributed systems. The power rating shall be 40W AES used in a low impedance 8 Ω.

The loudspeaker shall be 139mm (5.5") in diameter and 239mm (9.4in) deep. Weight shall be 2kg (4.4lb).

Lynx Pro Audio reserves the right to make changes or improvements in the design or the manufacturing that may affect these product specifications without notice.