

CLS-212

USER MANUAL

CLS-121S
CLS-218S

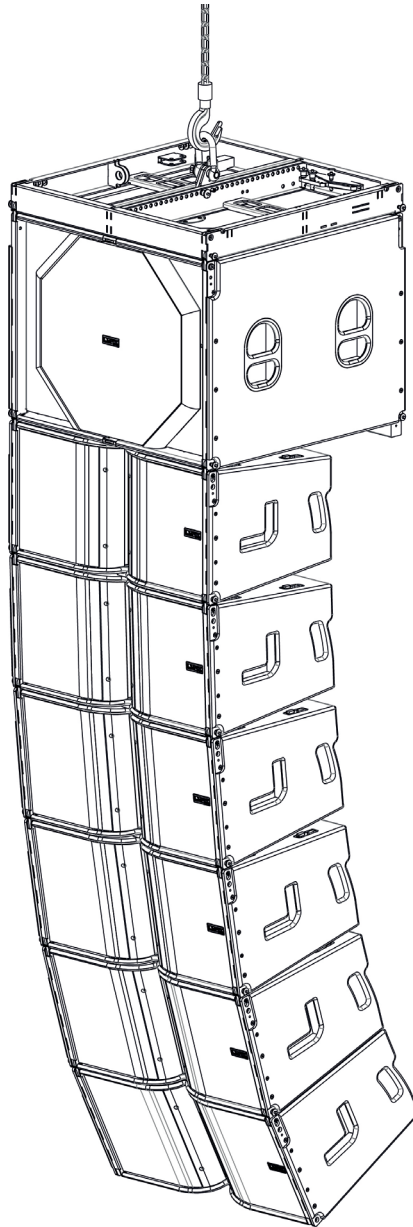

Lynx Pro Audio S.L.

Valencia, Spain - www.lynxproaudio.com - info@lynxproaudio.com

V.21.01

CLS-212

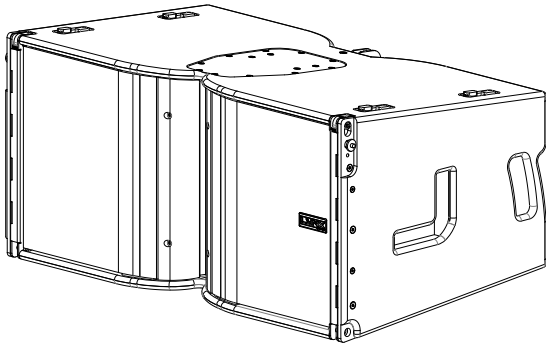

CLS-121S

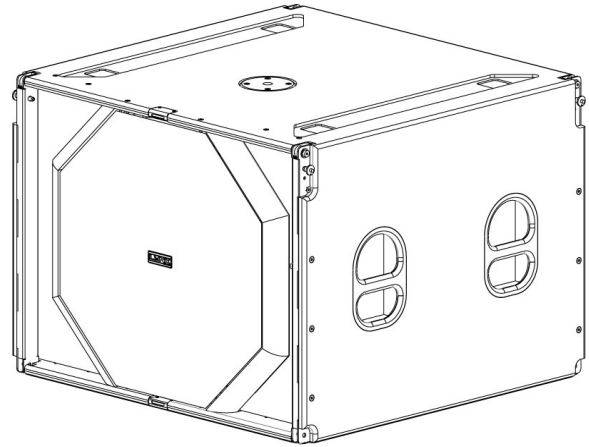

CLS-218S

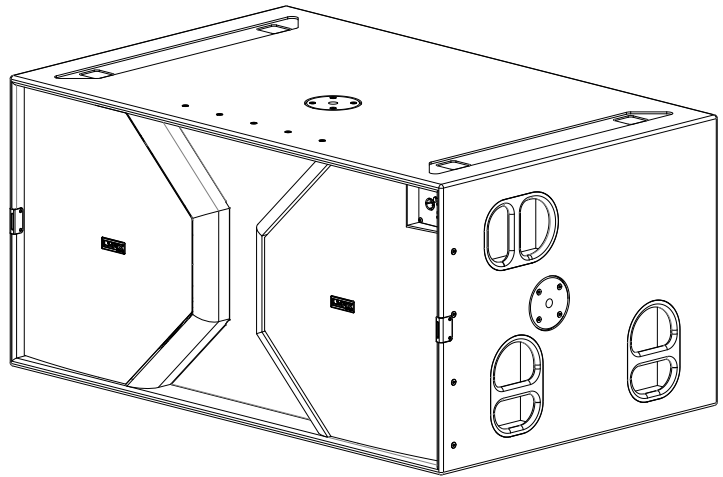

Manufacturer



LYNX Pro Audio S.L.
Calle 1 - Pol. Ind. Picassent
E-46220 Picassent (Valencia)



CE CERTIFICATION, EUROPEAN PRODUCT

INTRODUCTION

This manual describes the recommended installation procedure for the Coaxial Line Source cabinets CLS-212 in combination with the subwoofers CLS-121S and CLS-218S.

The CLS series is Lynx Pro Audio's answer to scalable line array systems.

Extreme care has been taken to select and customize the most advanced components on the market, including coaxial Mid/high drivers together with full electronic synergy through the coupling of the system amplification & integrated DSP technology.

Total system control is also achieved through our 3D prediction software (Rainbow 3D) working together with our remote system management platform (OCS). These cutting edge softwares together with the CLS technology provides the most optimum and precise listening experience to every ear in the audience.

CONTENTS

• SAFETY PRECAUTIONS	4
• SYSTEM OVERVIEW	
CLS-212	5
CLS-121S	7
CLS-218S	9
BACK PANEL	11
CONNECTORS AND CONNECTIONS	13
• CONFIGURING THE DIGITAL SIGNAL PROCESSOR	
FIR FILTERS	15
CONFIGURING THE DSP OPTIONS	15
CONFIGURATION PANEL	15
• ONLINE CONTROL SYSTEM	17
• RAINBOW 3D ACOUSTIC SIMULATION SOFTWARE	18
• HARDWARE AND ACCESSORIES	19
• CLS-212 RIGGING HARDWARE	20
• CLS-212 HOW TO FIX CABINETS	21
• HOW TO USE THE FLYING FRAME ON CLS-212	23
• CLS-121S RIGGING HARDWARE	28
• HOW TO USE THE FLYING FRAME ON CLS-121S	29
• FLOWN CONFIGURATION ON CLS-121S	30
• STACK CONFIGURATION ON CLS-121S	34
• APPLICATION EXAMPLES FOR CLS-121S	39
• APPLICATION EXAMPLES FOR CLS-218S	40
• CERTIFICATIONS AND GUARANTEE	44

Before starting to use this device, please read this instruction manual carefully. Keep these instructions in the place where the equipment will be used and with easy access to them.



• Electrical appliance

The exclamation mark within a triangle identifies the presence of electricity. Use the system carefully without wet hands or feet. Avoid installing the speaker in wet or excessively humid places. Do not place material that contains liquid on or near the unit. Avoid dripping or splashing water or any liquid over the unit. Regularly check the condition of the cables and make sure these are not being walked on or pinched. Connect the speaker to bipolar, earthed mains. The mains plug must be connected to the appropriate protection (fuse or breaker). Connection to any other type of mains could result in an electrical shock and violate local electrical codes.

CAUTION: DO NOT CONNECT OR DISCONNECT THE AC POWER CONNECTORS UNDER LOAD.



• Heavy equipment

Apply back protection when using the system. Avoid loading and unloading at heights.



• Electrical shock risk

The diagonal mark within a triangle identifies the presence of dangerous voltage.

Do not open or handle the interior of the box. These parts are not to be adjusted by the user. For maintenance and/or repair please go to an authorized service centre. In order to reduce the risk of electric shock, disconnect from AC before plug in or unplugging Audio signal cables. Reconnect to AC only if all signal connections are made and secured. Never manipulate the ground type plug provided.

The AC mains plugs should always remain accessible for operation.

Unplug the loudspeaker during storms or when it's being used for a long time.



• Hearing damage risk

These systems can reproduce large quantities of sound pressure which can damage hearing. Take precautions if you are going to be near them for extended amounts of time and do not get too close.



• Hanging / Flying

Do not hang the cabinets from the handles or from any other part other than the designated hanging point. When flying this system please observe the technical and "Rainbow" software data carefully. Never exceed the maximum safe working loads or ignore the instructions included within this manual. Use Only flying accessories provided by Lynx Pro Audio S.L. Rigging must be always carried out by professionals.



• Delicate Material

Please ensure no foreign object or water enters the speaker. Only clean the unit with dry cloths. Do not use solvents.



• Overheating / Fire risk

To reduce the risk of the speaker over heating, avoid direct contact with sunlight. Avoid placing the unit close to heat inducing objects such as radiators. Do not cover the equipment in use and do not block any ventilation openings. Do not put naked flame, such as lighted candles, close or on top of the unit.



• Electromagnetic and interferente emissions

Avoid placing objects which through electromagnetic waves can damage the unit, such as mobile phones, lap tops, magnetic strip cards etc.

This system complies with normatives

EN 55103-1 (1)

EN 55103-2 (2)

(1) This device may not cause harmful interferences.

(2) This device may receive interference including interferences that may cause undesired working.



• IMPORTANT NOTE

This Equipment must be used in accordance with these instructions and by trained professional personnel only. This equipment should not be used in places with extreme tropical climates. Don't expose this apparatus to extreme humidity and or temperature values.

SYSTEM OVERVIEW

- **CLS-212**

Extremely compact & extremely powerful 3-way, self-powered (6000 W Class-D with PFC), DSP integrated coaxial line array element. Dual high power 12" neodymium transducers and two unique 6.5" dual diaphragm coaxial planar wave driver.

- **Technical Data:**

Frequency range:	60 Hz - 22 KHz (- 6 dB)
Horizontal coverage:	100°
Vertical coverage:	Single element 10°
Max SPL / Peak:	142 dB / 148 dB
Components:	
• LF:	2 x 12". 4" DUO double layer in/out copper voice coil, waterproof cone treated on both sides, neodymium magnet. 1400 W (AES)
• MF/HF:	2 x 6.5" dual diaphragm coaxial planar wave driver. - Mid: 3.5" (90 mm) voice coil, 150 W (AES) - High: 1.5" (44.4 mm) voice coil, 80 W (AES)
Power amplifier:	6000W Class D with switching power supply & PFC LF amplifier: 1 x 3000W MF/ HF amplifier: 1 x 3000W
DSP:	Internal Lynx Processor DSPB-FL. 96 KHz / 64 bit double-precision, DSP with FIR filter linear phase High performance 32 bit 96 KHz AD/DA converters
Crossover:	Digital, FIR filter 500Hz Passive, 6.3 KHz
Control:	User control interface with 2.8" IPS and multifunction joystick controller
Control connections:	USB (DSP programming) Dual Ethernet port, Online Control System
Input:	BAL/ UNBAL XLR connectors analog input AES3 digital input optional
Nominal voltage:	100 - 240V AC @ 50-60 Hz
Operating voltage:	85 - 264V AC
AC Connectors:	16A Neutrik powercon true1 TOP with looping output
Finish:	Polyurea coating, high grade resistant paint
Material:	15 mm Premium birch plywood
Dimensions:	384 x 800 x 480 mm (H x W x D) / with pins 815.5 mm (W)
Weight:	47 Kg (103.6 lbs)

- **Key features**

- Extraordinary power-to-size ratio
- Unique 6.5" dual diaphragm planar wave driver
- Perfect acoustical coupling of individual units providing continuous line source & excellent phase coherence
- Extended bandwidth (65 Hz – 22 KHz)
- Integrated Digital processor (64 bit / 96 KHz) with FIR linear phase filtering
- Perfect Time Alignment avoiding Multi-Source Interference problems
- Ergonomic design in premium birch plywood & finished in polyurea
- 2.8" IPS display with multifunction joystick control

- CLS-212 measurements

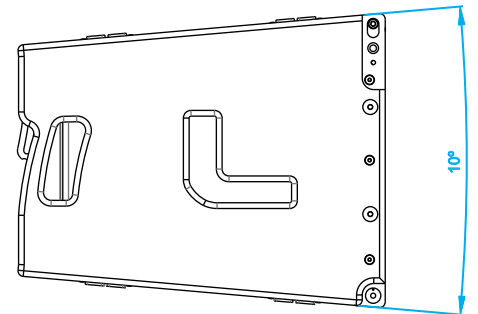
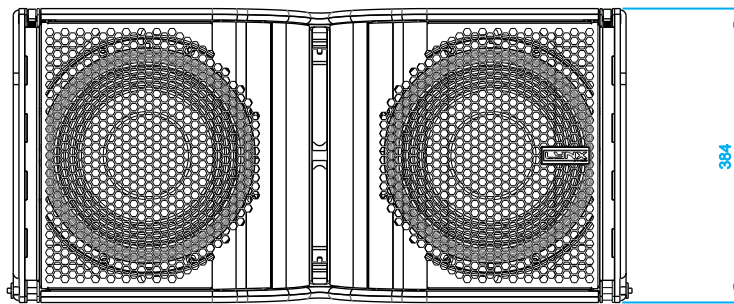
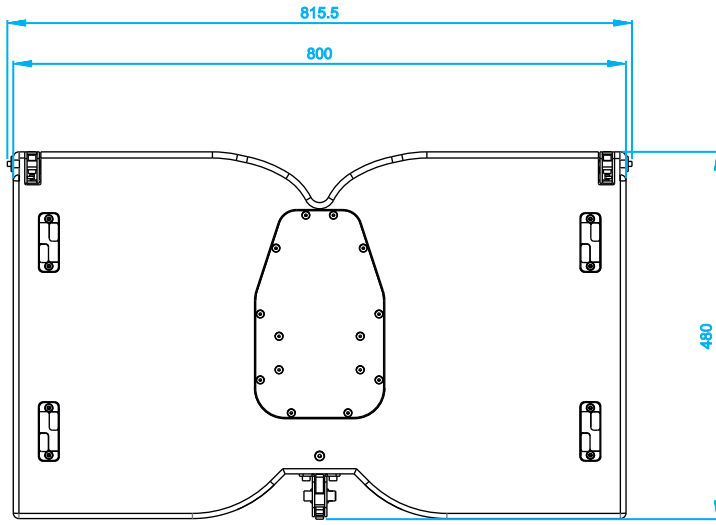

- **CLS-121S**

Compact & extremely powerful, self-powered (3000W Class-D with PFC), DSP integrated subwoofer unit in direct radiation configuration. 21" (4" voice coil) neodymium transducer.

- **Technical Data:**

Frequency range:	30 Hz - 90 Hz (preset 90 Hz)
Coverage:	Quasi omnidirectional
Max SPL / Peak:	131 dB / 137 dB
Components:	
• LF:	21" Neodymium magnet transducer. 4" quattro in/out copper voice coil, waterproof cone treated on both sides. Malt Cross Technology cooling system. Aluminium demodulating ring for very low distortion. 1600 W (AES)
Power amplifier:	3000W Class D with switching power supply & PFC
DSP:	Internal Lynx Processor DSPB-FL. 96 KHz / 64 bit double-precision High performance 32 bit 96 KHz AD/DA converters 120dB
Configuration:	Bass-reflex direct radiation enclosure
Control:	User control interface with 2.8" IPS and multifunction joystick controller
Control connections:	USB (DSP programming) Dual Ethernet port, Online Control System
Input:	BAL/ UNBAL XLR connectors analog input + loop AES3 digital input + loop
Nominal voltage:	100 - 240V AC @ 50-60 Hz
Operating voltage:	85 - 264V AC
AC Connectors:	16A Neutrik powercon true1 TOP with looping output
Finish:	Polyurea coating, high grade resistant paint
Material:	15 mm / 18 mm premium birch plywood
Dimensions:	608 x 800 x 778 mm (H x W x D) / with pins 814.5 mm (W)
Weight:	64 Kg (141 lbs)

- **Key features**

- Extraordinary high power output
- Integrated Digital processor (64 bit / 96 KHz)
- Front & rear audio and power connectors for cardioid applications
- Ergonomic design in premium birch plywood & finished in polyurea
- 2.8" TFT display with multifunction joystick control
- Stackable and flyable standard and/on cardioid configuration

• CLS-121S measurements

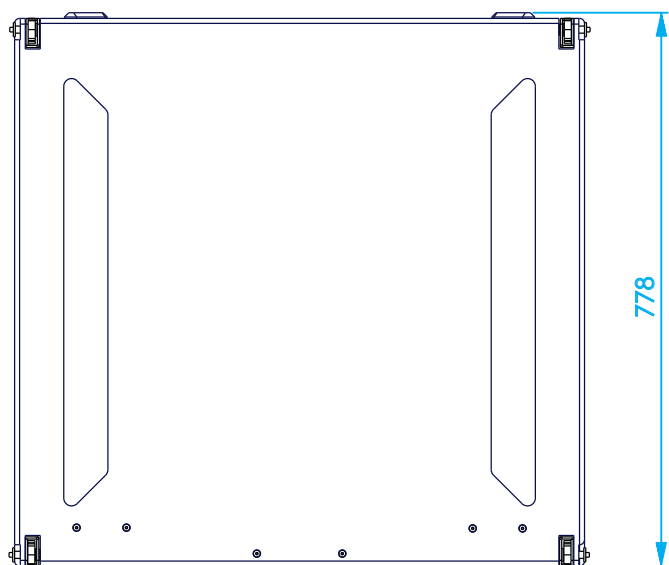
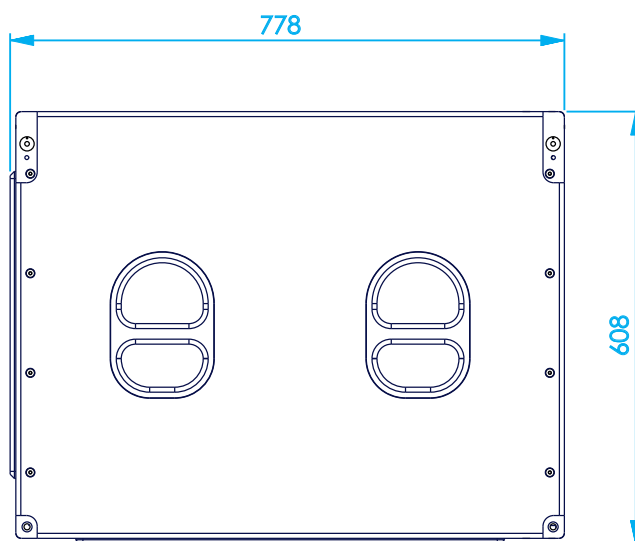
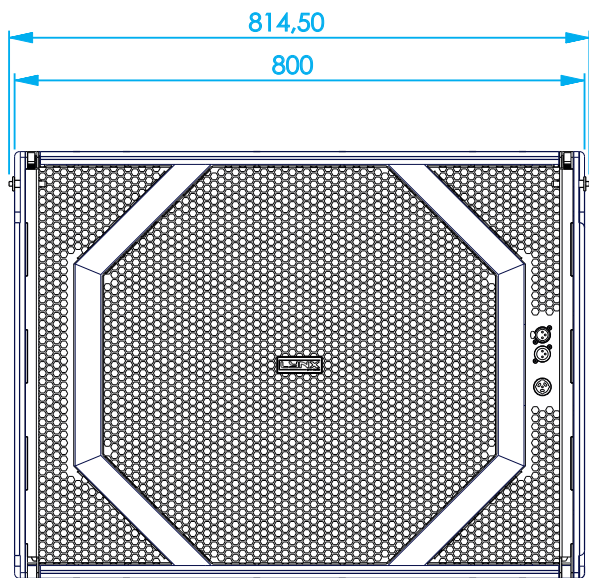

• CLS-218S

This is an extremely compact & powerful sub-bass unit in direct radiation configuration. The CLS-218S is self-powered (6000W Class-D) with DSP integrated. It uses dual 18" neodymium transducers (4.5" voice coil).

• Technical Data:

Frequency range:	30 Hz - 100 Hz (preset 100 Hz)
Coverage:	Quasi omnidirectional
Max SPL / Peak:	136 dB / 142 dB
Components:	
• LF:	Dual 18" Neodymium magnet transducer. 4.5" split winding copper voice coil. waterproof cone treated on both sides. Aluminium demodulating ring for very low distortion. 1700 W (AES)
Power amplifier:	6000W Class D with switching power supply & PFC
DSP:	Internal Lynx Processor DSPB-FL. 96 KHz / 64 bit double-precision High performance 32 bit 96 KHz AD/DA converters 120dB
Configuration:	Bass-reflex direct radiation enclosure
Control:	User control interface with 2.8" IPS and multifunction joystick controller
Control connections:	USB (DSP programming) Dual Ethernet port, Online Control System
Input:	BAL/ UNBAL XLR connectors analog input + loop AES3 digital input + loop
Nominal voltage:	100 - 240V AC @ 50-60 Hz
Operating voltage:	85 - 264V AC
AC Connectors:	16A Neutrik powercon true1 TOP with looping output
Finish:	Polyurea coating, high grade resistant paint
Material:	15 mm / 18 mm premium birch plywood
Dimensions:	600 x 1200 x 770 mm (H x W x D)
Weight:	81 Kg (178.5 lbs)

• Key features

- Extraordinary high power output and sonic linearity
- Integrated Digital processor (64 bit / 96 KHz)
- Front & rear audio and power connectors for cardioid applications
- Ergonomic design in premium birch plywood & finished in polyurea
- 2.8" IPS display with multifunction joystick control
- Stackable and flyable standard and/on cardioid configuration

• CLS-218S measurements

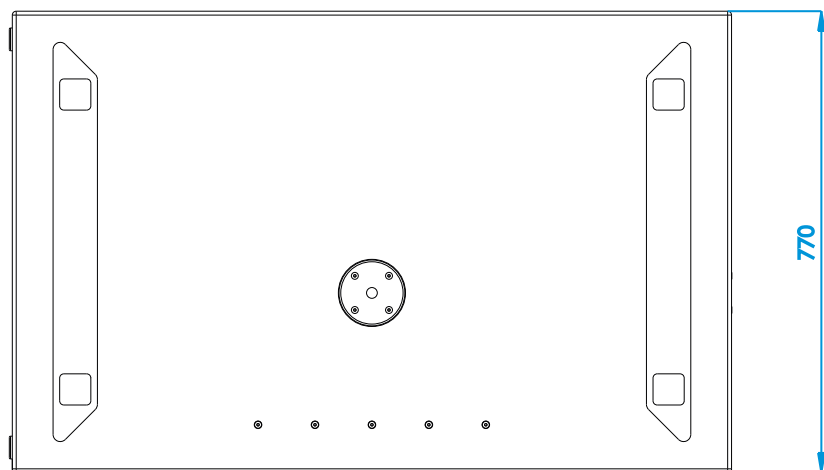
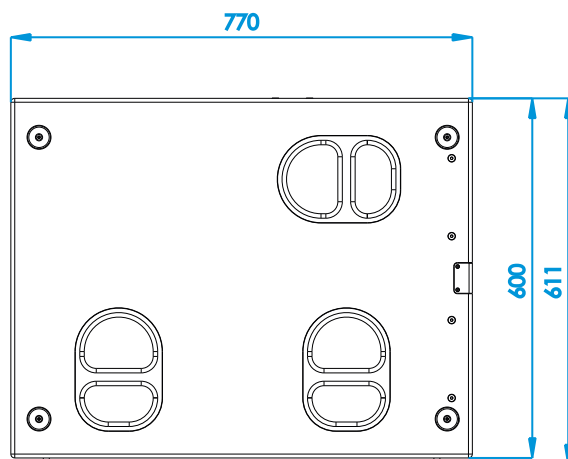
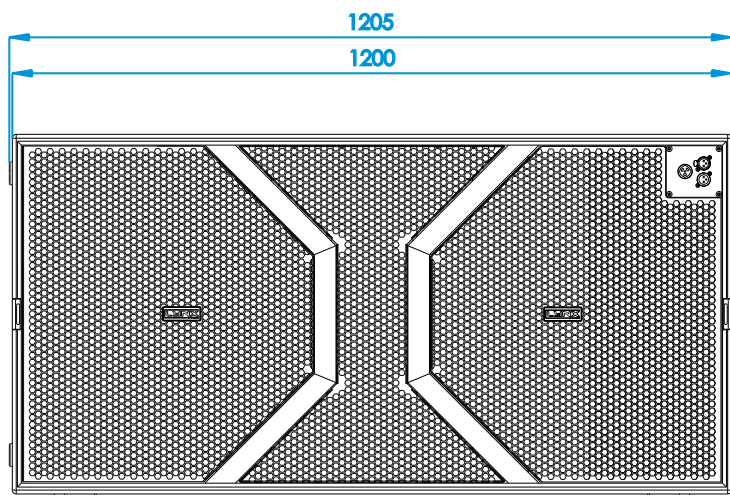

CLS BACK PANEL

This is the back panel of the CLS-212 tops, including the connectors and digital control display.

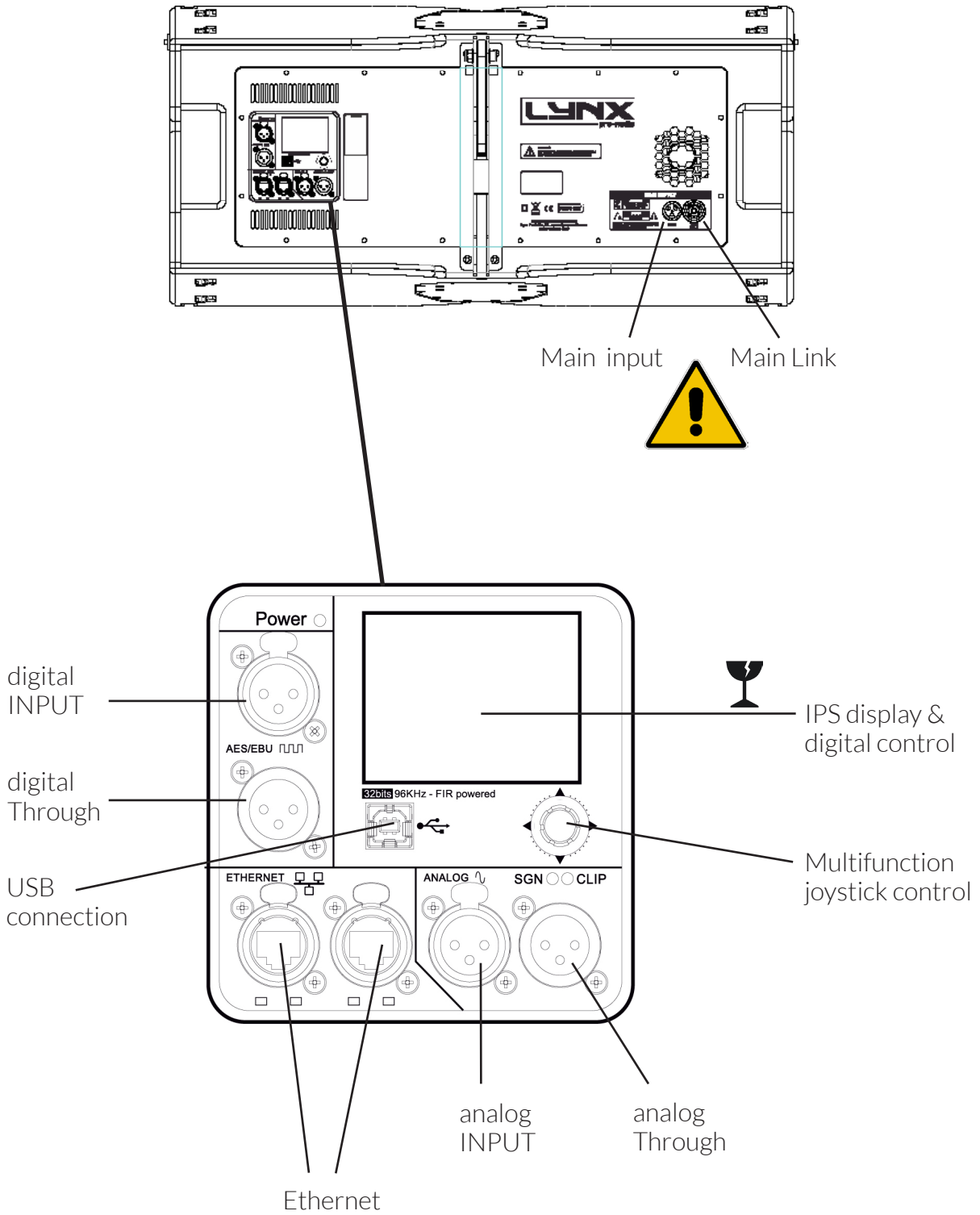

Both subwoofer cabinets CLS-121S and CLS-218S have the same rear panel, including the connectors and digital control display.

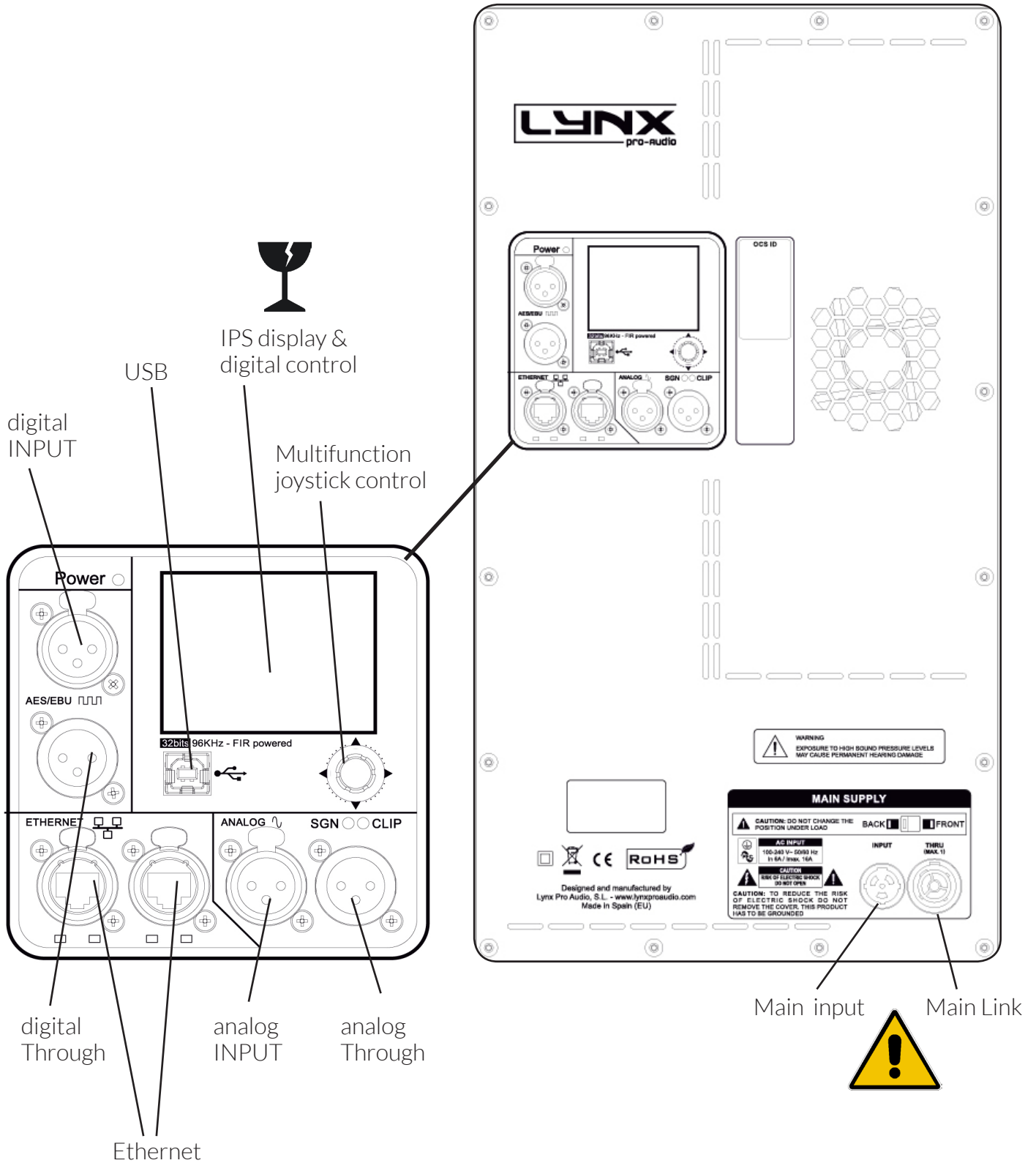

CONNECTORS AND CONNECTIONS

All the connectors and connections are placed on the back panel of the cabinets.

Furthermore, subwoofers CLS-121S and CLS-218S have extra connectors integrated into the front grill so you can setup the cabinets in cardioid configuration (back panel at the front view). By this way the subwoofers are connected always at the rear part of the system avoiding to have all the wires on the front view.

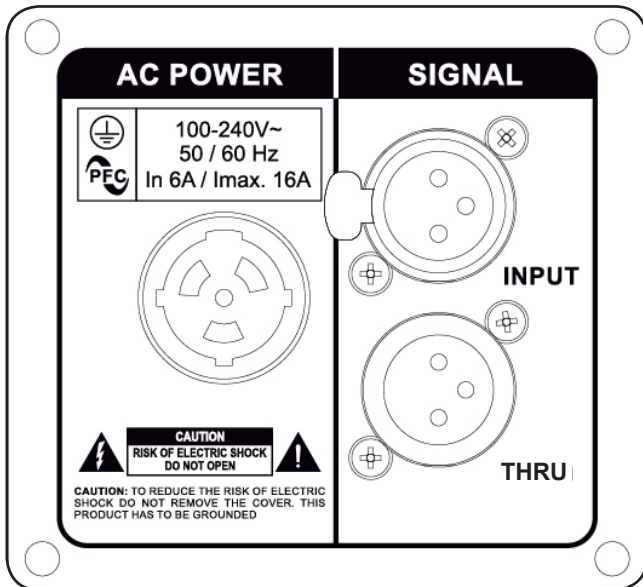

CAUTION: Do not connect or disconnect the AC Power connectors under load.

You will find a compact connector panel integrated into the front grill of the subwoofers in order to connect the system in cardioid configuration.

XLR SOCKET CONNECTORS

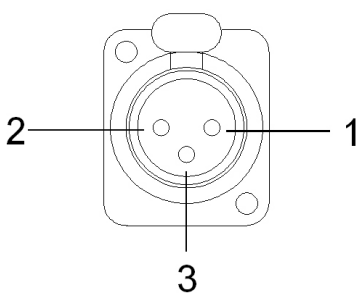

INPUTS
1.- EARTH
2.- LIVE (+)
3.- LIVE (-)

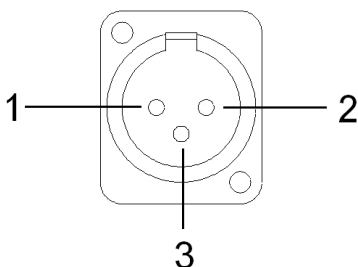

OUTPUTS
1.- EARTH
2.- LIVE (+)
3.- LIVE (-)

XLR AERIAL CONNECTORS

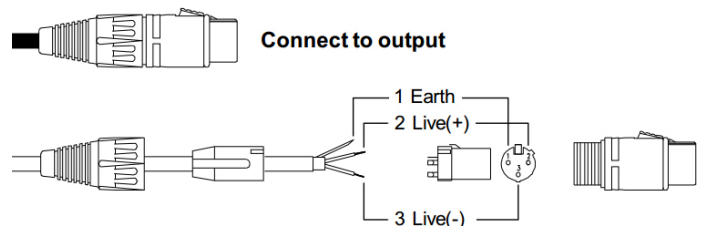
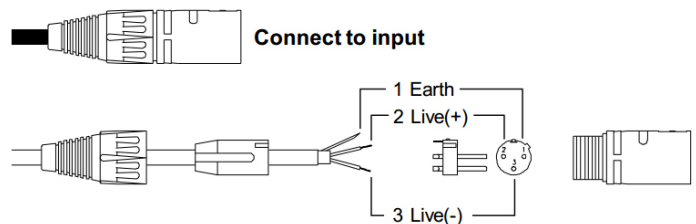

SOCKET POWERCON TRUE1

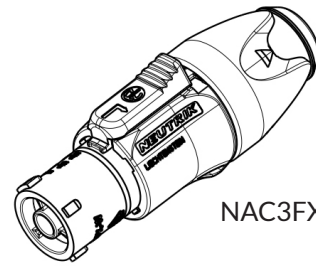
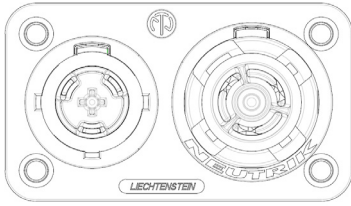

NAC3FX-W TOP

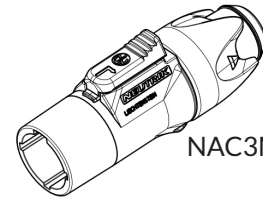

NAC3MX-W TOP

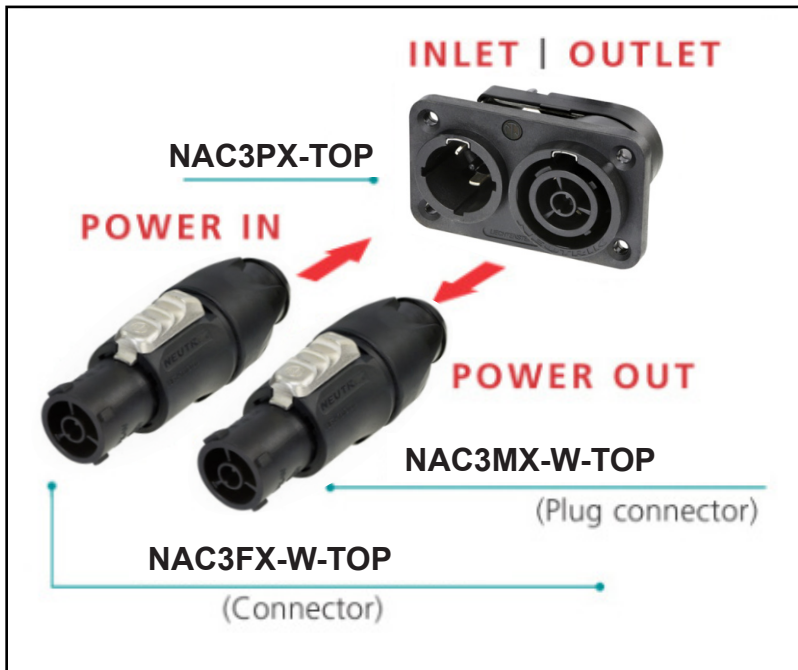

ETHERNET CONNECTOR

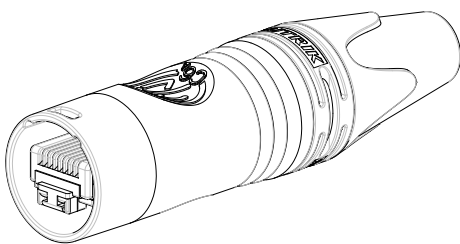

NE8MX6

FIR FILTERS

Finite Impulse Response (FIR) filters are used in the signal processing of the cabinets. FIR is a type of digital filter with linear phase characteristics. This frees system designers from the constraints of phase anomalies associated with analogue filters or their digital versions (IIR, Infinite Impulse Response). When properly used, FIR filtering can audibly improve a system's impulse response and reduce crossover interference.

CONFIGURING THE CABINET DSP OPTIONS

On the back pannel of the cabinet you will find the digital control area. From the compact joystick located below the screen you are able to configure the Basic adjustment functions of the internal DSP. Just move the joystick to select the icons on the left of the screen. You can enter into the following functions:



Please note that you must apply the desired configuration in each one cabinet and requires electrical power to work.

If changes are not made the display will automatically dim to avoid unnecessary light in situations where light is not wanted. To re-activate the light simply press the joystick.

CONFIGURATION PANEL

On the main screen you can see the cabinet's input and output.

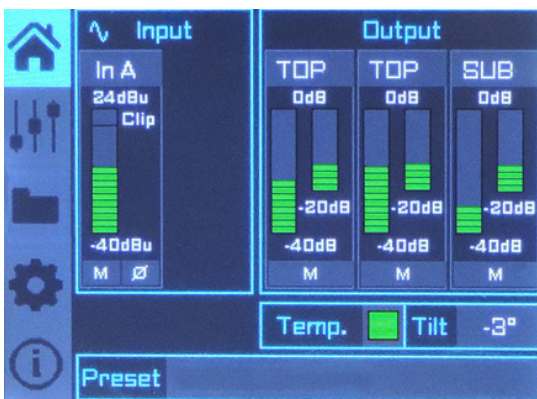

- **Input:**

You can see a vumeter with the input level and a clip signal.

- **Output:**

You have a vumeter with the output level (0 dBu is the amp's maximum level) You can check the compressor and control the dynamic activity.

On the second screen you can modify some parameters.



- **Gain**

- **Mute**

- **Polarity**

- **Delay**

- **High Pass Filter:** You can setup a High Pass filter selecting type, frequency and order.

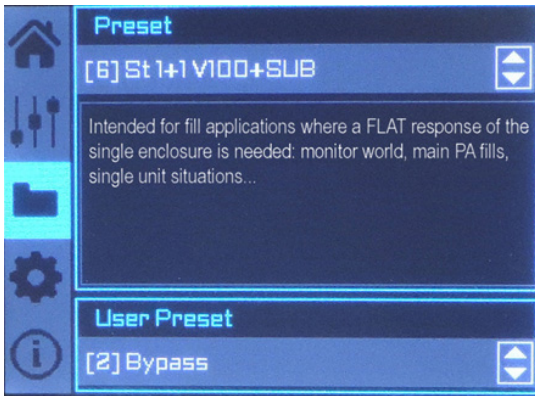

The folder screen shows you the name of the preset and its description.

Using the joystick you can change the preset.

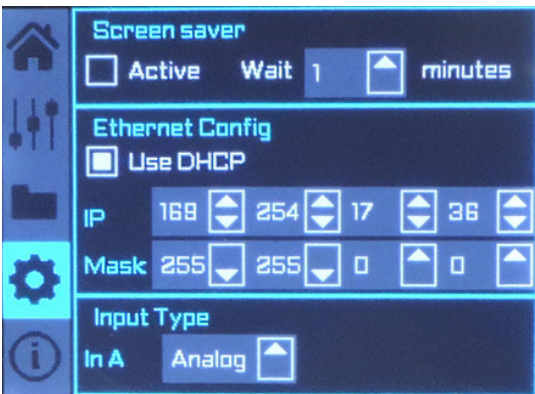

This screen is to configurate Ethernet. You can choose automatic or manual

You can also configure the screen saver.

And here you have the input selection. You can choose between analog or AES3 for channel 1 or channel 2.

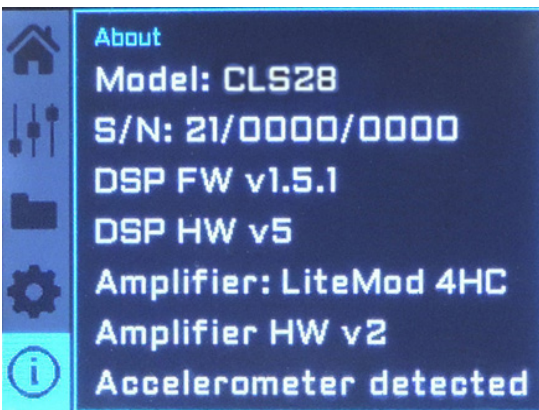

The last screen shows you some general information regarding the cabinet's components.

Here you can see the cabinet model, its serial number, DSP firmware and hardware versions, amp module model with hardware version, as well as the accelerometer status.

ONLINE CONTROL SYSTEM

- Who is it for?

Users of Self powered DSP incorporated Lynx Pro Audio Cabinets where the user has requested the cabinets be supplied with the Ethernet Module kit.

- What is it for?

Obtain detailed information of cabinet behaviour and monitor the cabinet/s in real time. You can change the preset, gain, mute, polarity and phase. You can also activate the air absorption compensation and select the «SOLO» mode.

- How does it work?

Via Ethernet (cable or wireless). Once installed, the O.C.S. software automatically detects all the cabinets connected to the network and displays them in the O.C.S. window on the users PC.

- What does it show?

As well as displaying the cabinet model and IP address the O.C.S will be monitoring in real time and the user will be able to view RMS levels, Input clip, power module temperature, compression levels, air absorption compensation and cabinet angulation.

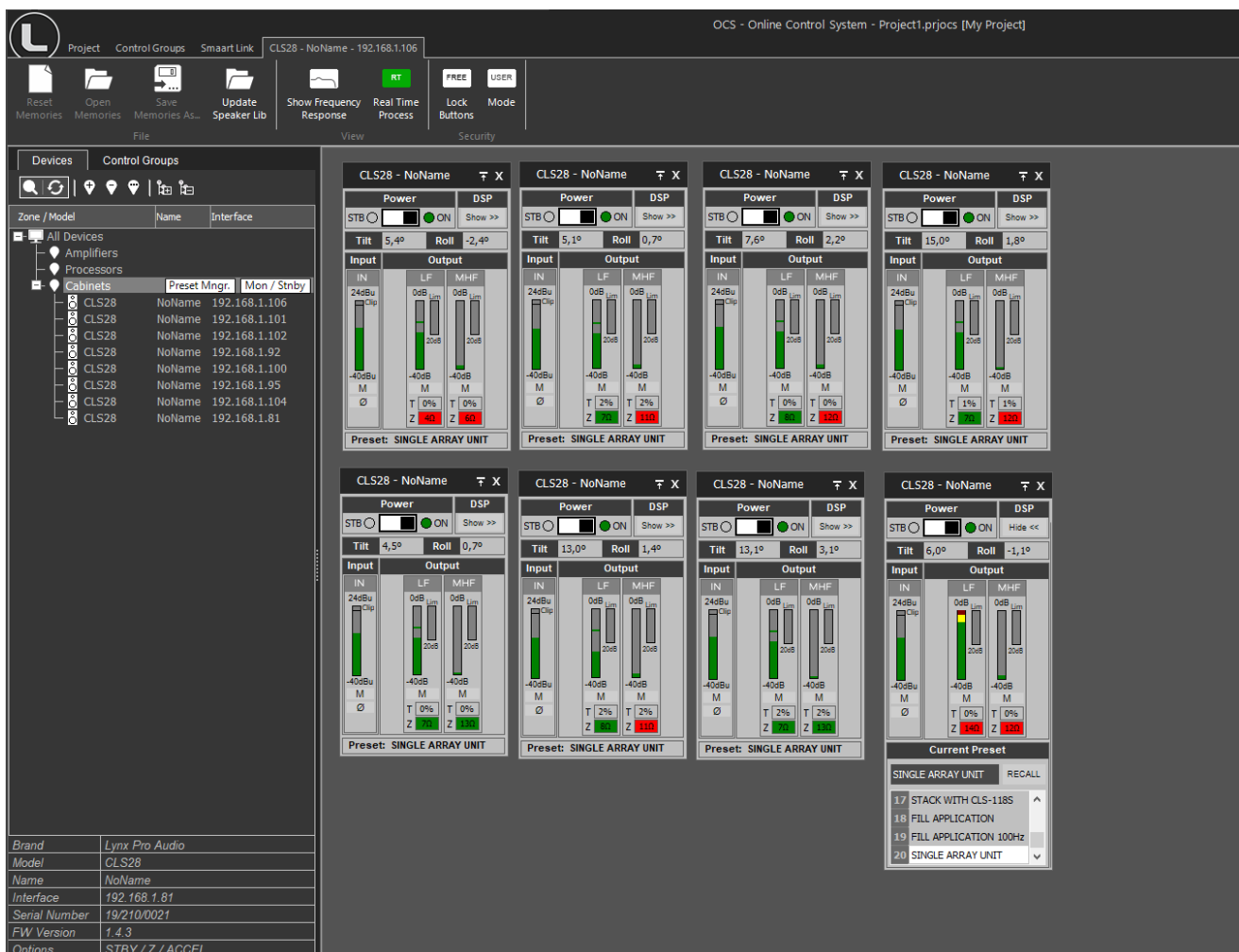

RAINBOW 3D Acoustic Prediction Software

Lynx Pro Audio's R&D department is working on Rainbow 3D, a new acoustic simulation software with dynamic 3D features. With a sophisticated design, Rainbow 3D stands out for its speed, being able to provide a simulation in just a few seconds. It also provides algorithms for beam steering and optimizing the listening area.

- **Designed from scratch by professionals**

Rainbow 3D has been programmed from scratch by Lynx Pro Audio engineers, using new programming procedures that achieve an effective simulation with really low calculation time.

- **Multiple listening zones**

The program can simulate all Lynx Pro Audio's acoustic enclosures located in a 3D space, including the classic side, top and front views. It can also define multiple listening zones and allows offset positioning and symmetry. Blueprint images, textures and PNG format pictures can be imported.

- **Unlimited sound sources**

Allows the acoustic simulation for an unlimited number of sound sources and audio systems. You can place as many systems (subwoofers, line arrays, columns and individual boxes) as you desire. Also, the line arrays can be placed in stack or flown configuration.

- **Beam steering**

Rainbow 3D has the ability to add DSP processing to the simulation and uses algorithms to control the directivity (beam steering) in columns, without the need to tilt them physically, being able to divide the column into several beams that point to different zones.

- **Accurate optimization thanks to FIR filters**

Optimized algorithms are used in the listening area to improve the sound coverage and the frequency response. This feature can be executed in a matter of seconds. Additionally, the export of FIR coefficients can be performed with the optimization for later loading in the DSP via Ethernet or a USB device. In the near future direct communication with Lynx Pro Audio and OCS will be available.

- **Multiple measures and tools**

Likewise, the R&D department is developing multiple measurement and analysis tools for the calculated data. For example, the sound pressure curves (SPL) in the listening areas and the capture of virtual measurements that show the frequency response in the points of location indicated and added. Among other tools you will find autoplay and a wizard to set up different subwoofer arrangements.

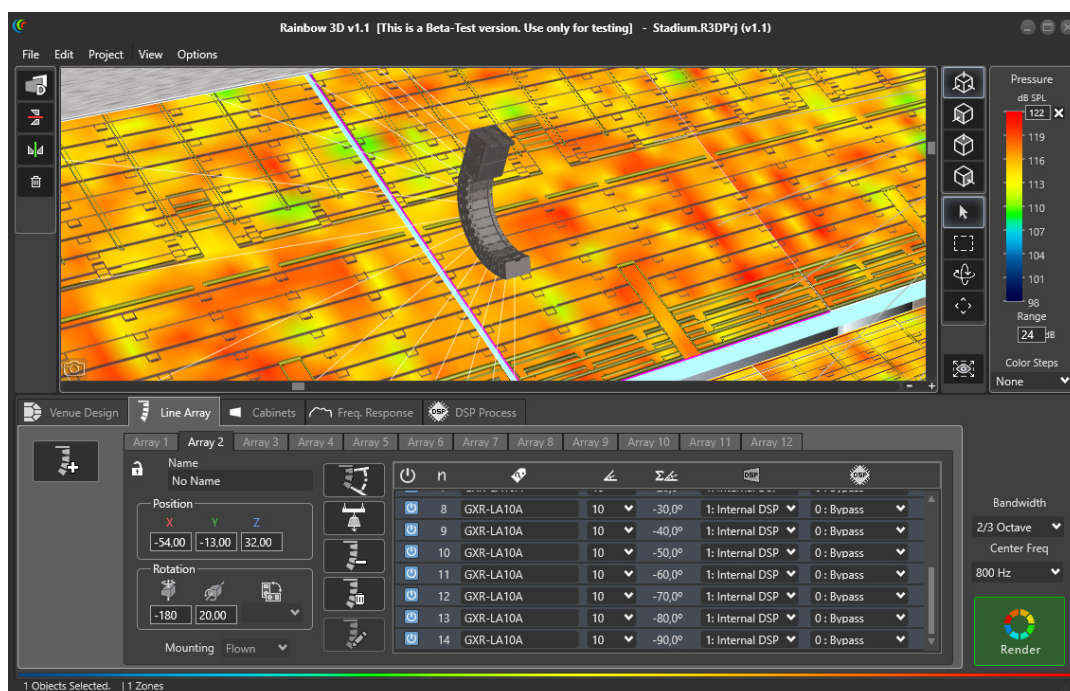

HARDWARE AND ACCESSORIES

The CLS cabinets offer a variety of practical accessories to help use the system in a number of events, from touring applications to fixed installations, indoor and outdoor.

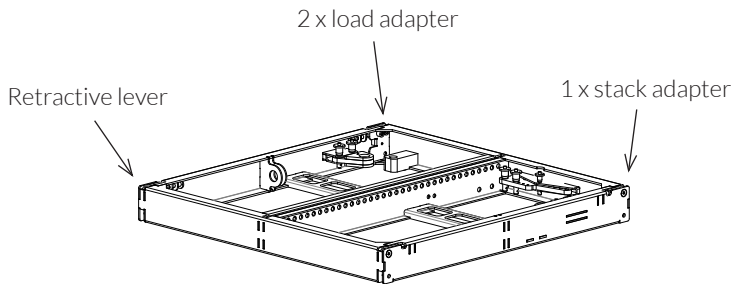

- **SV-CLS20**
Flying frame for 16 CLS-212 or 10 CLS-121S.
Max. 1000 Kg. For fly or stack.

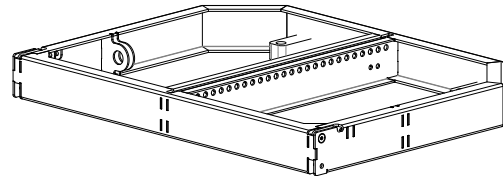

- **SV-CLS20 Lite**
Flying frame for 16 CLS-212. Max. 1000 Kg.
Convenient for installations in small spaces.

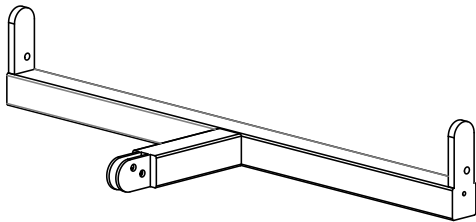

- **SC-CLS212/121S**
Connection system for CLS-212 together with
CLS-121S. 6 enclosures maximum.

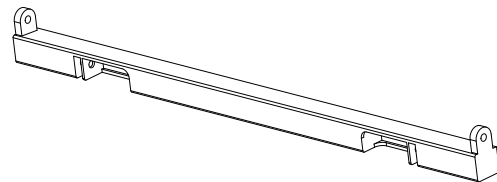

- **SC-CLS212/28**
Connection system for CLS-212 together
with CLS-28. 6 enclosures maximum.

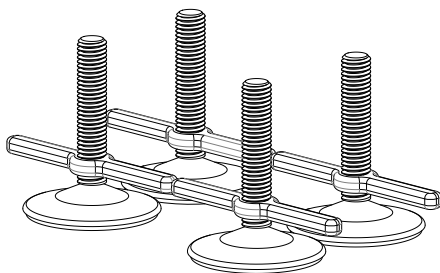

- **ST-CLSKIT**
4 x ground stack stabilisers for SV-CLS10.

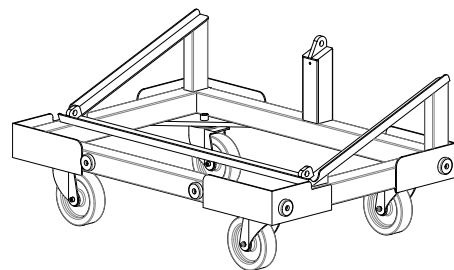

- **CA-4CLS212**
Transport dolly. Up to 4 CLS-212.

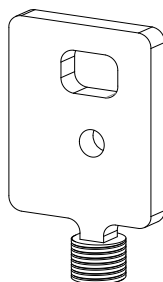

- **ST-SVCLS/M20**
Kit to connect SV-CLS10 or SV-CLS20
flying frame and M20 plate.
Join 118S/121S/218S with bumper.

CLS-212 RIGGING HARDWARE

- Each CLS-212 cabinet has four ergonomic handles with firm internal grip to facilitate transport, positioning and loading of the cabinets.

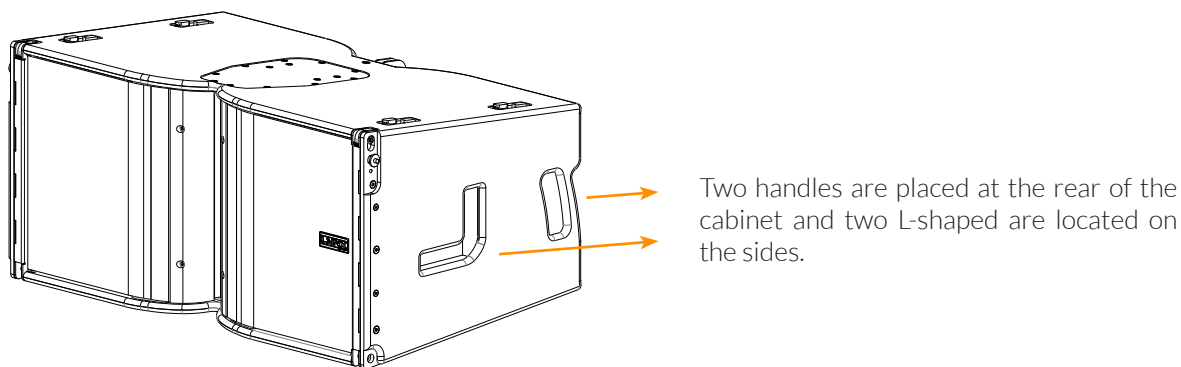

CLS-212: How to fix cabinets

- Remove pins from the front. Retractive levers will rise up.

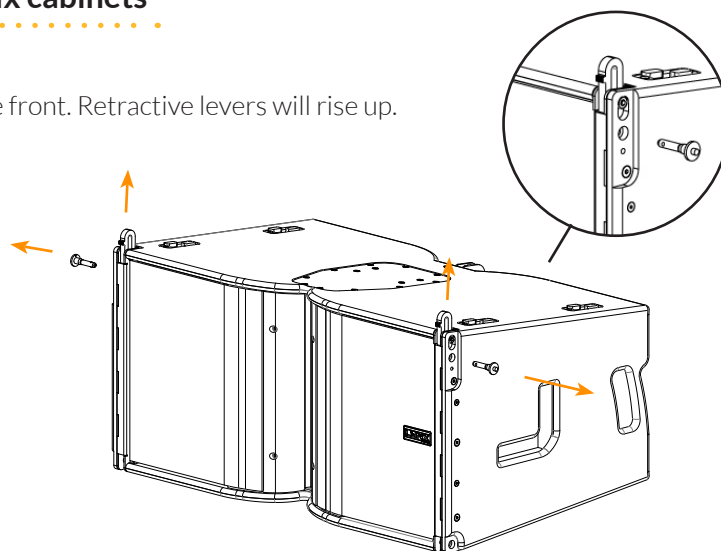

- Remove pins from the centre/rear. The rear lever is activated manually.

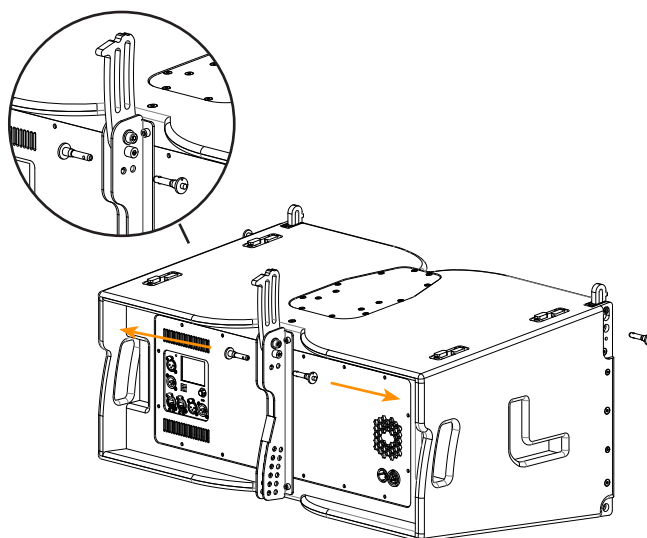

CLS-212: How to fix cabinets

- This rear lever has two working positions depending if we want to fix the cabinet to another cabinet (A) or to fix the cabinet to the flying frame (B).

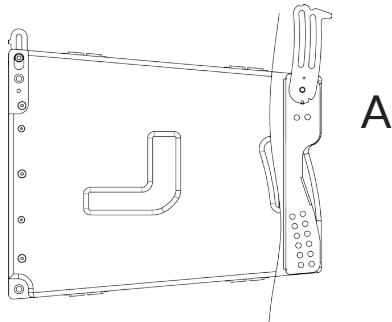

- Join with another CLS-212 cabinet

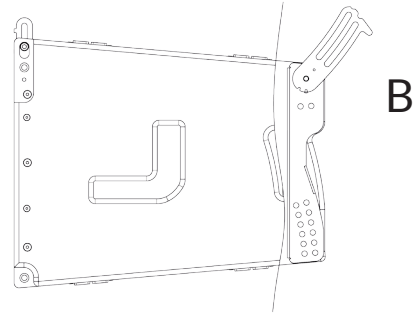

- Join with flying frame SV-CLS20

The 3 point rigging system (2 front retractive levers + 1 rear point) enables up to 16 CLS-212 cabinets to be flown in a single array.

Array angulation is configured on the back of the cabinet using the splay/stack hardware located at the centre of the rear panel. Different splay angles are easily set up available with optional splay angles, from between 0° to 10° with 1° step increments to create the desired curve.

This angulation system has two sides, showing the yellow and blue colours.

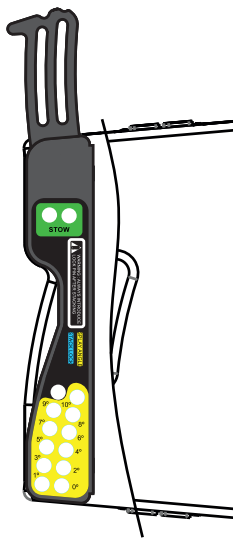

The Yellow side allows splay angles for a line array in flown configuration.

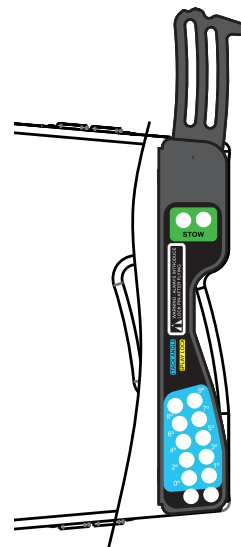

The Blue side allows to set up the stack mode.

CLS-212: How to fix cabinets

- The first thing to do is to choose the angle. Then, you must lock it.

- SPLAY ANGLES (flown cabinets)

Use the yellow part of the rigging system.

Choose your splay angle and then insert the pin. Ensure that the pin is correctly inserted. Then, on the other side of the rigging system, insert another pin through the yellow circle (splay lock) with the same chosen angle.

This rigging system allows to set up the cabinets in retracted position.

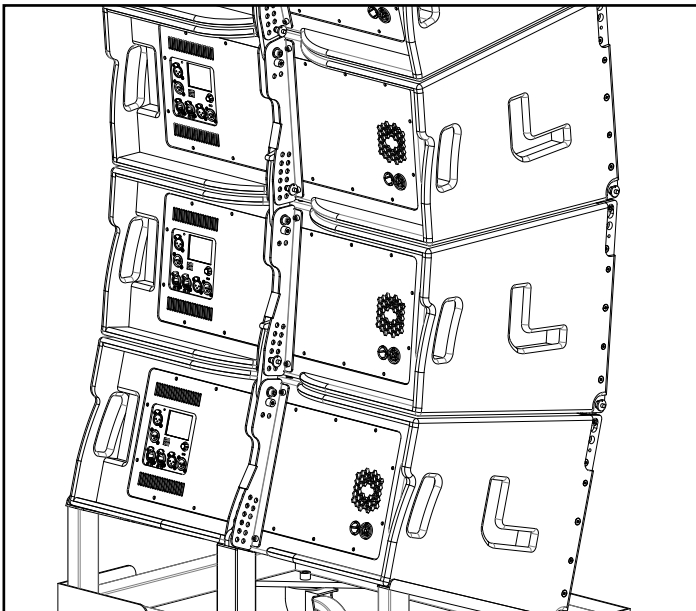

- While you are lifting the array the rigging system will apply the angulation to each cabinet and then you only need to lock it for security.

- When the cabinets are completely stacked you can prepare the set up without lifting any cabinet. Just choose the splays angles and insert the pins.

Then lift the array slowly and when the array takes its shape just lock each one of the cabinets.

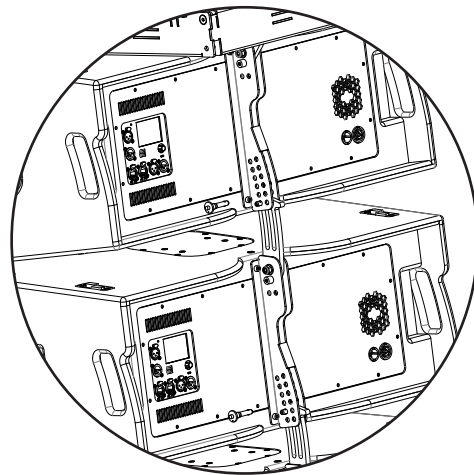

- STACK ANGLES

Use the blue part of the rigging system.

Choose your stack angle and then insert the pin. Ensure that the pin is correctly inserted. Then, on the other side of the rigging system, insert another pin through the blue circle with the same chosen angle.



How to use the flying frame on CLS-212

- 1 • Remove lid / top cover

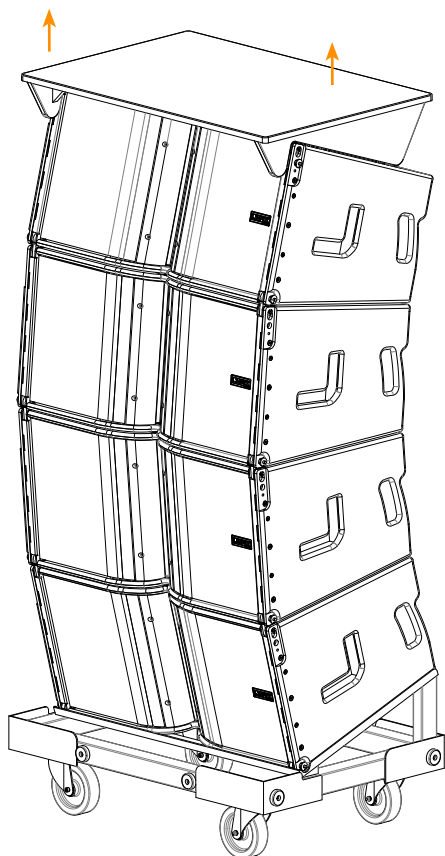

- 2 • Remove pins from the front of the top cabinet. Retractive levers will rise up. Then remove pins from the rear lever and place it in the middle position.

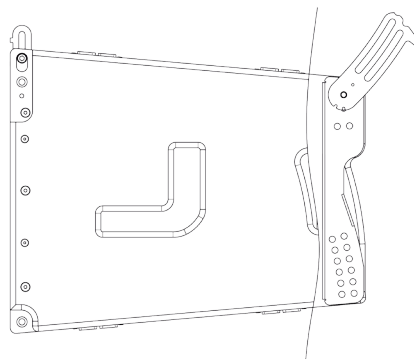

- 3 • Place SV-CLS20 and introduce security pins. Bring it closer to the cabinet.

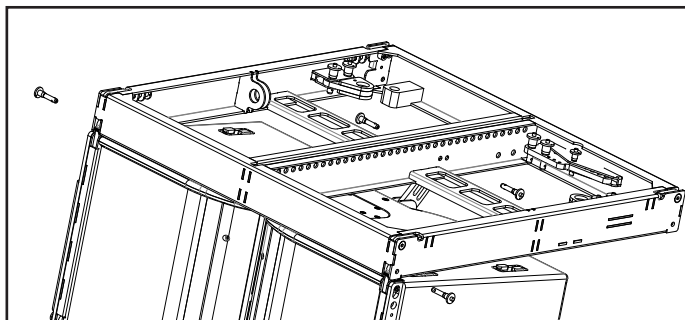
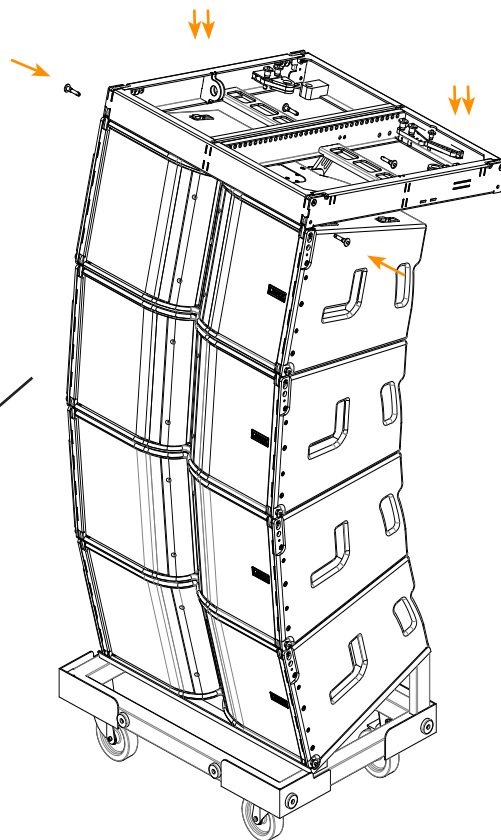

NOTE: Ensure all pins on all cabinets are inserted correctly and fully in their corresponding holes.

How to use the flying frame on CLS-212

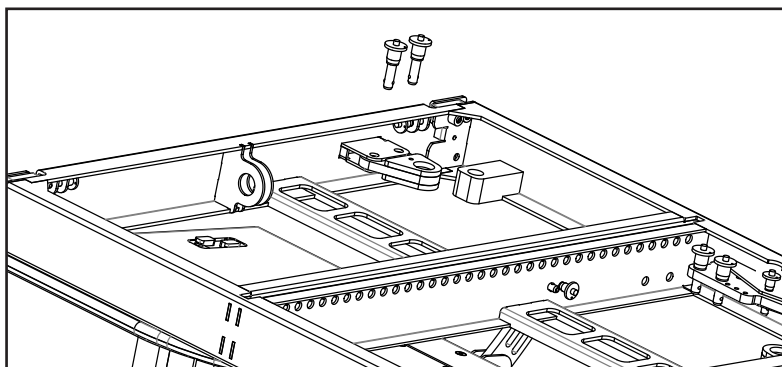

NOTE: Remove load adapter correctly from their positions to fit in the SV-CLS20 accessory.

- 4 • Remove load adapter

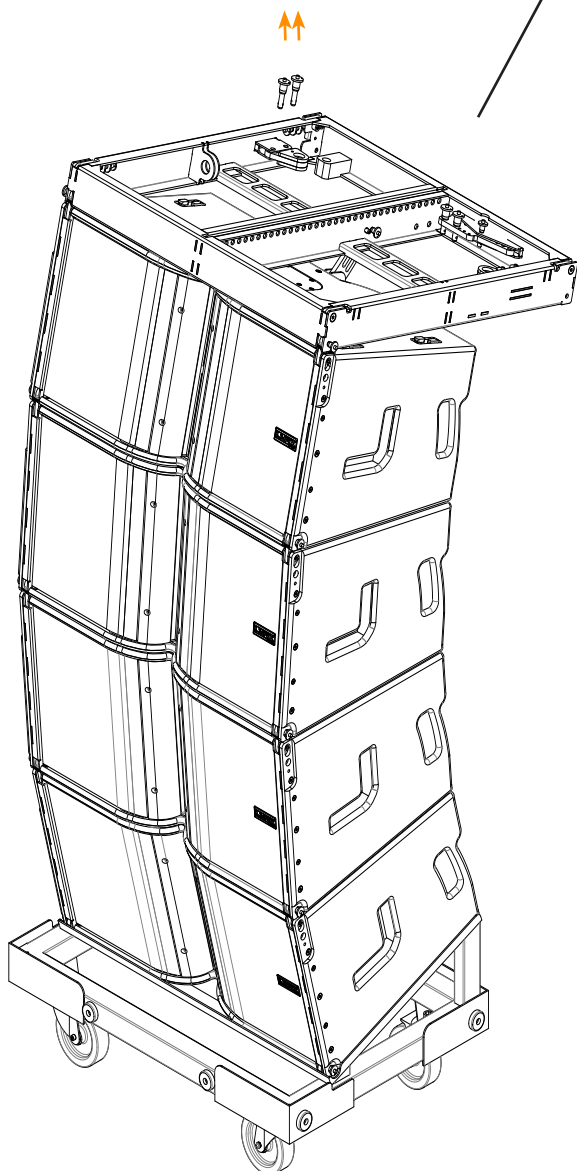

How to use the flying frame on CLS-212

- Set angles (0, 3, 4) in rest position as simulated in Rainbow 3D
- After rising the cluster always introduce security pins.

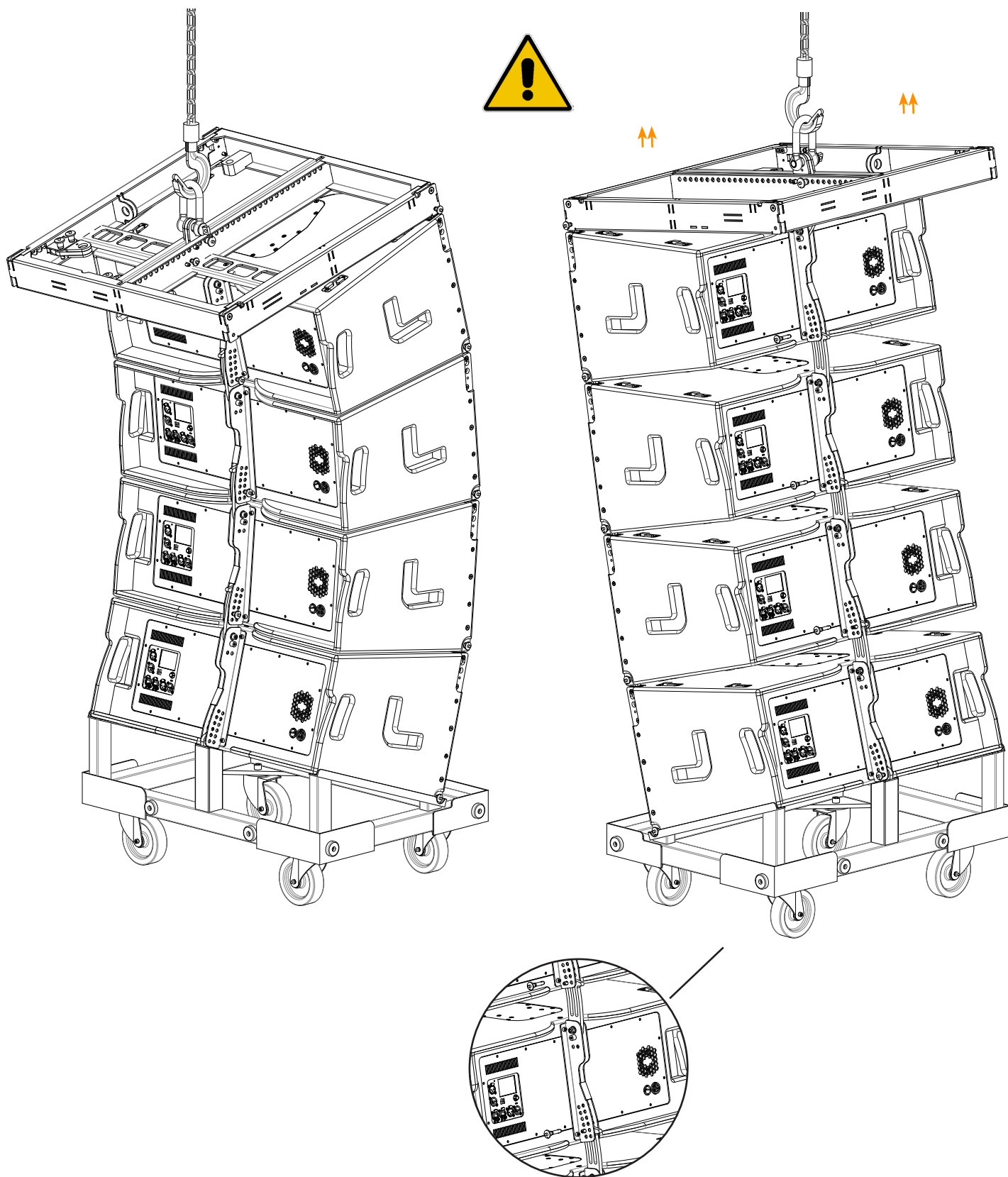

How to use the flying frame on CLS-212

- Let retractive levers rise up

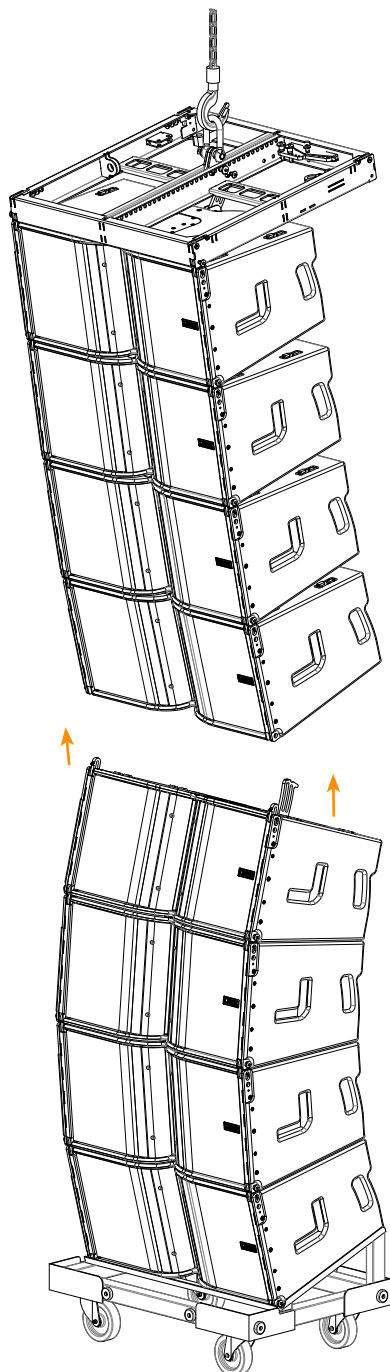

- Introduce security pins

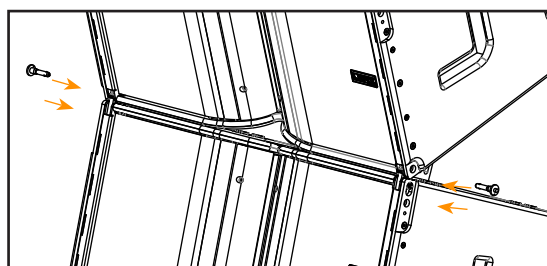
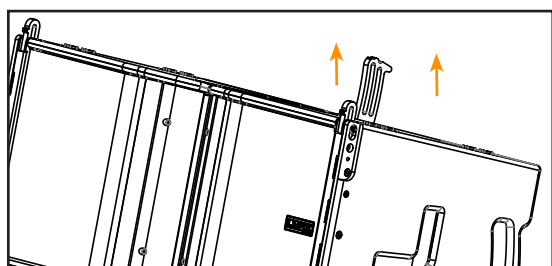
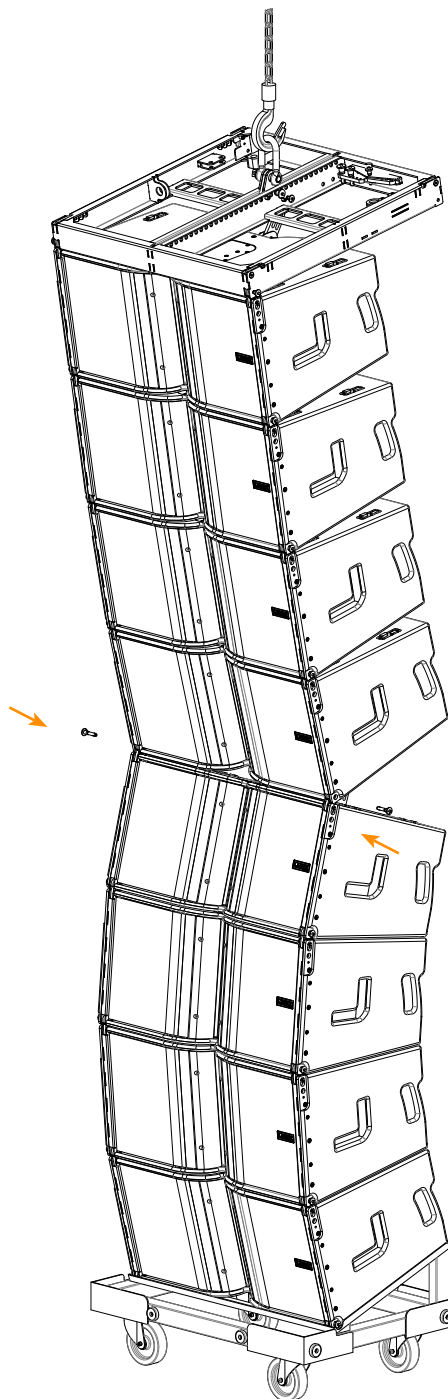

How to use the flying frame on CLS-212

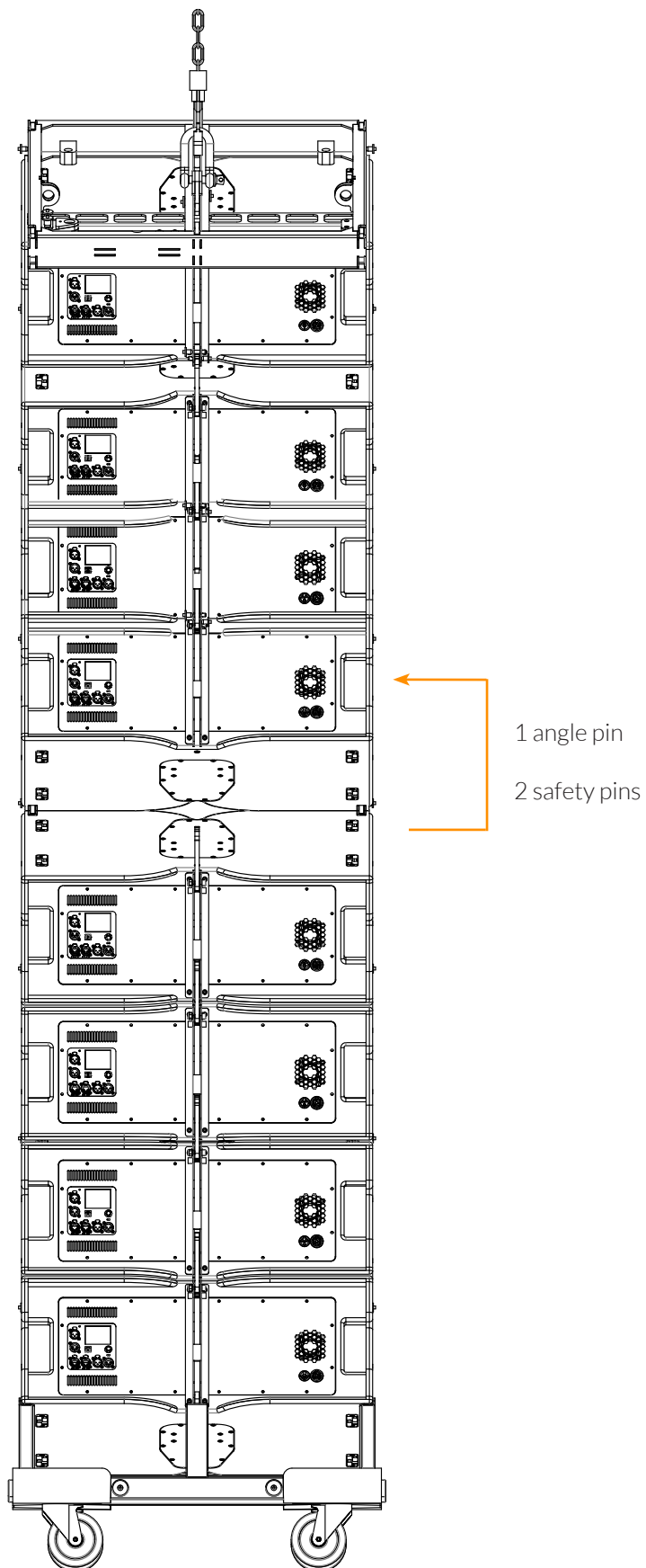

CLS-121S RIGGING HARDWARE

- CLS-121S enclosure:

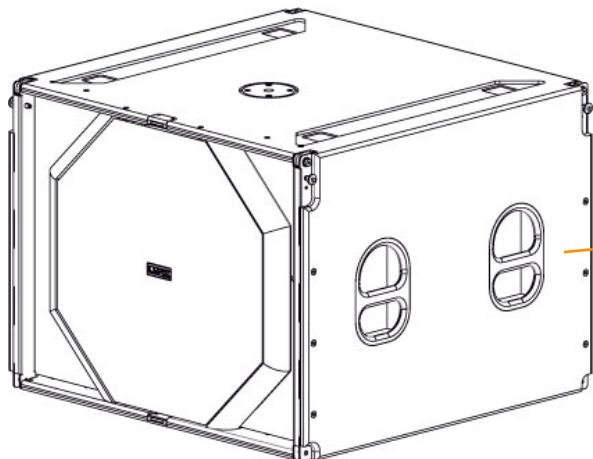

Four ergonomic handles with firm internal grip to facilitate transport, positioning and loading of the cabinets.

Two handles are placed on each side of the cabinet.

- Remove pins from CLS-121S (front and back). Retractive levers will rise up in the front.

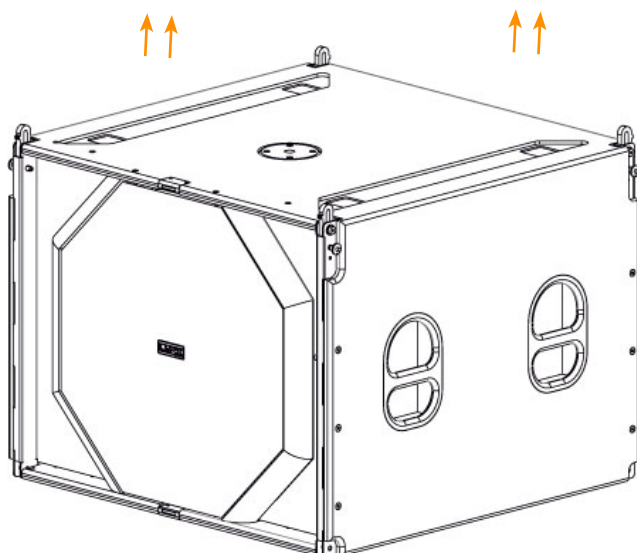
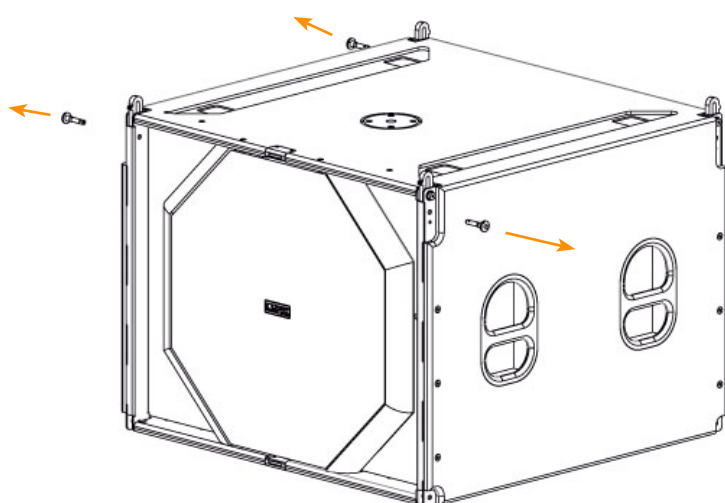

- The 4 point rigging system which includes 2 front automatically rising plates and 2 rear points which enable 10 CLS-121S cabinets to be flown in a single array or together with the CLS-212.

How to use the flying frame on CLS-121S

- Remove all pins from top and let levers rise up. Then, place the flying frame SV-CLS on top. This accessory is a flying frame for 16 CLS-212 or CLS-121S. It can support up a maximum of 1000 kgs.

SV-CLS20 flying frame

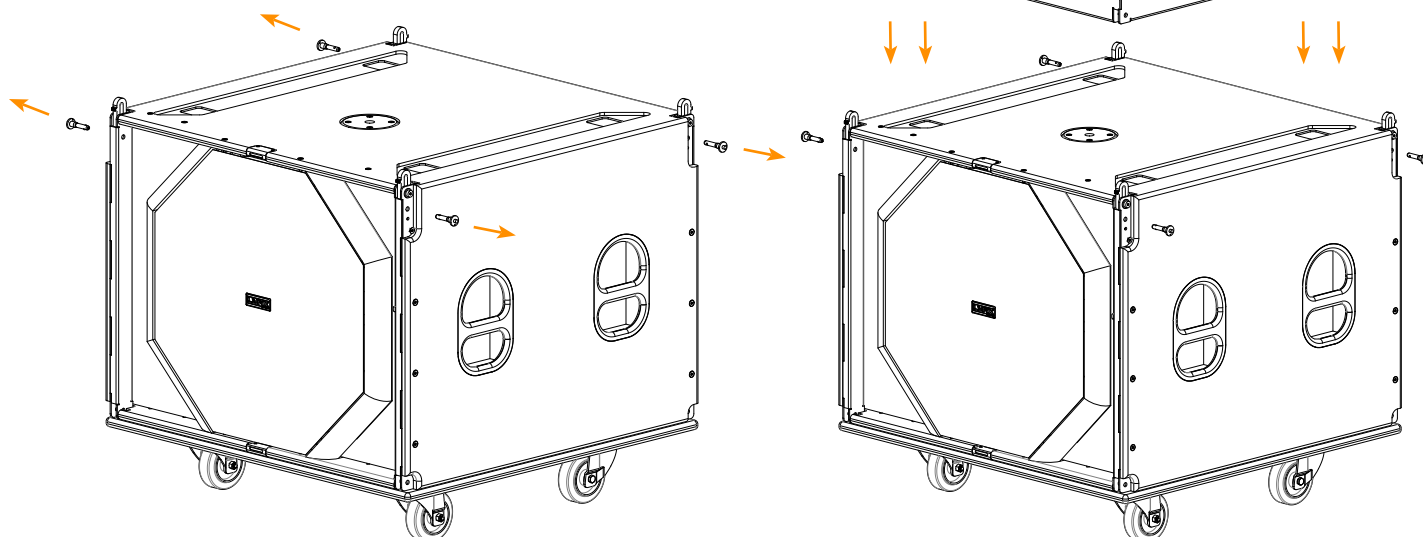

- Place the flying frame SV-CLS20 carefully on top of the CLS-121S to fit in the levers with the screws. Please, make sure to fit all the screws on the levers until the flying frame is attached.

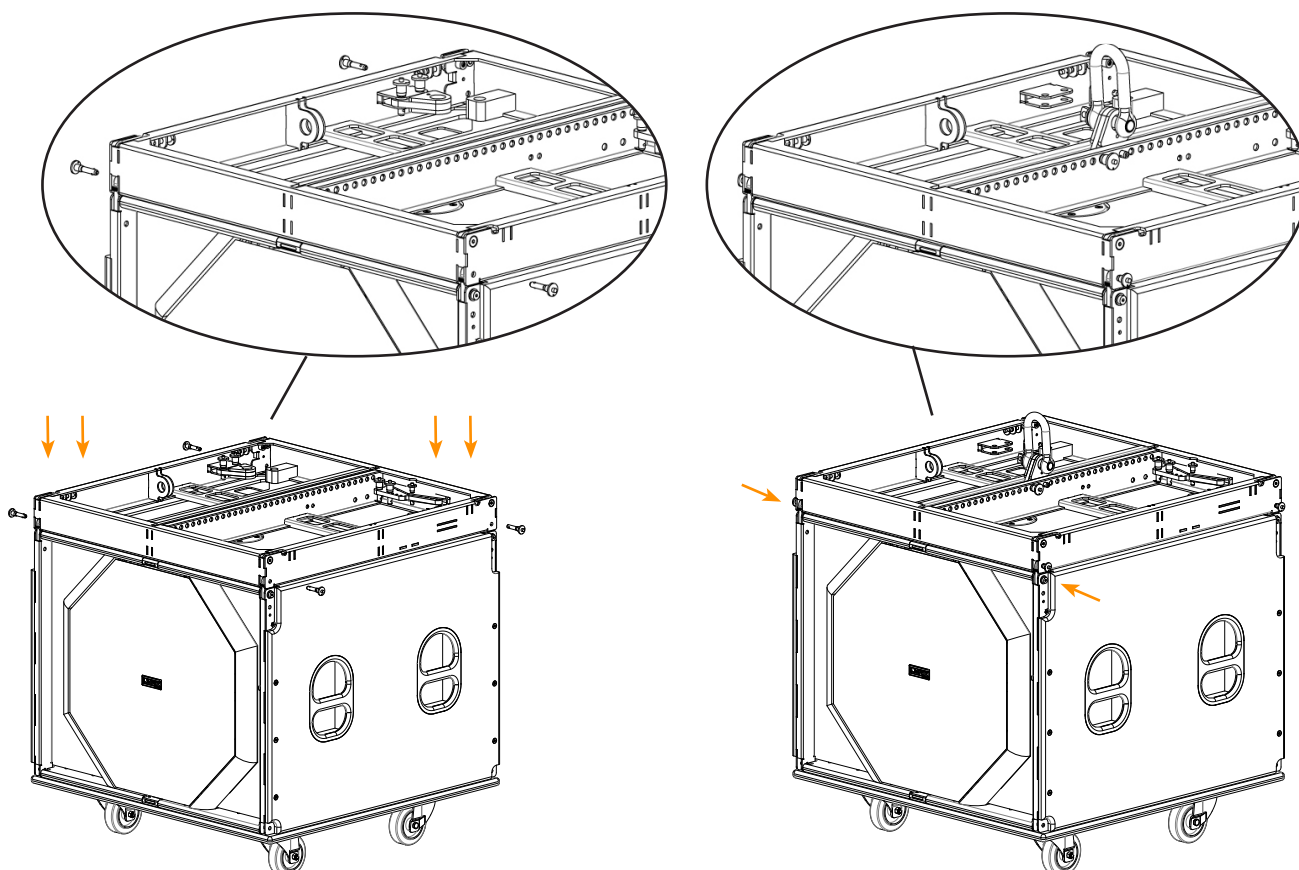

CLS-121S FLOWN CONFIGURATION

- Place the SC-CLS212/121S connection system below the subwoofer. Make sure to fit in the screws correctly to attach the CLS-121S cabinet. Then, fit the CLS-212 cabinet just below the SC-CLS212/121S accessory and make sure to insert the pins on the holes correctly.

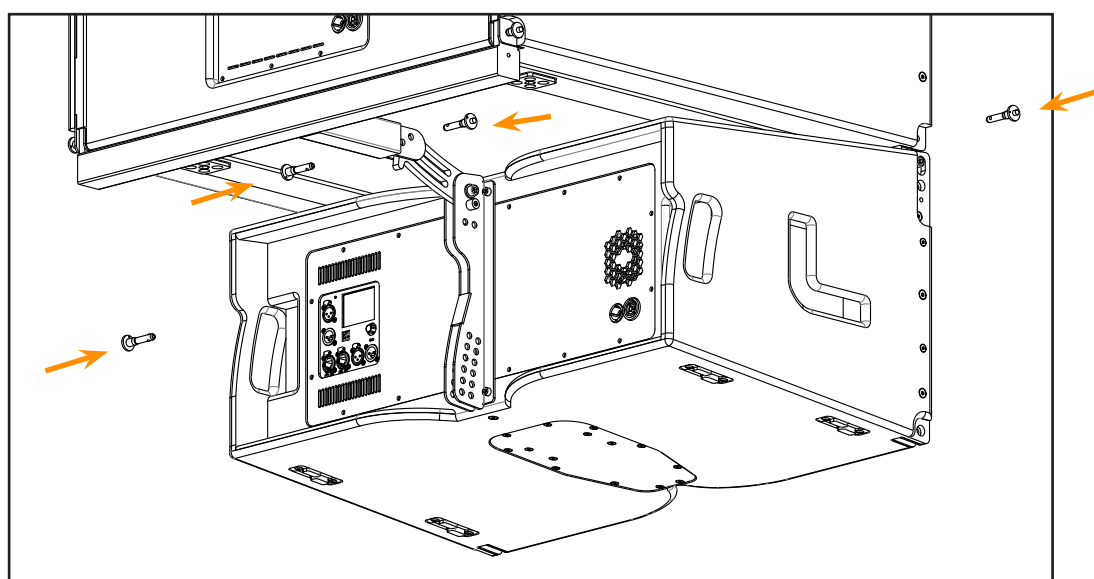
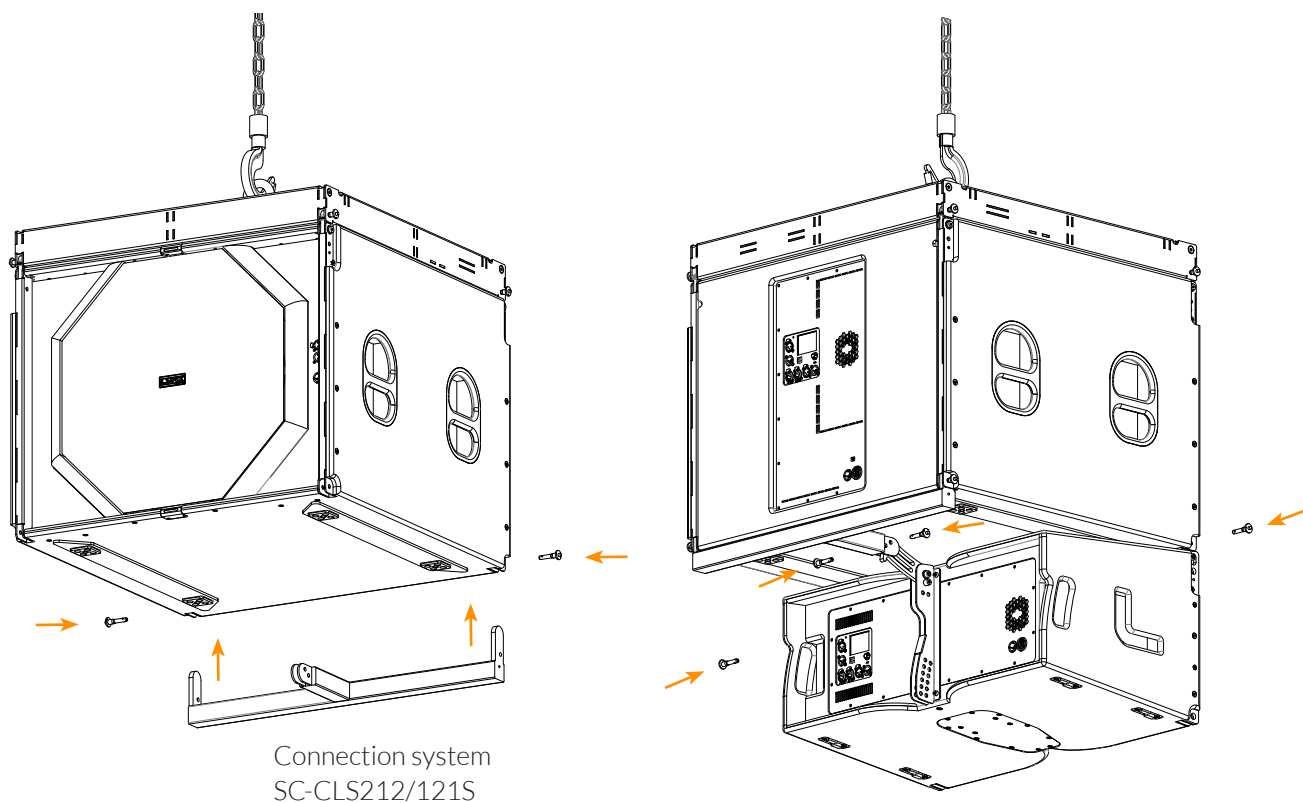

NOTE: Ensure all pins on all cabinets are inserted correctly and fully in their corresponding holes.

CLS-121S & 6 CLS-212 FLOWN CONFIGURATION

- Make sure you have inserted the security pins on the holes correctly before adding any cabinet. You can place a maximum of 6 CLS-212 cabinets.

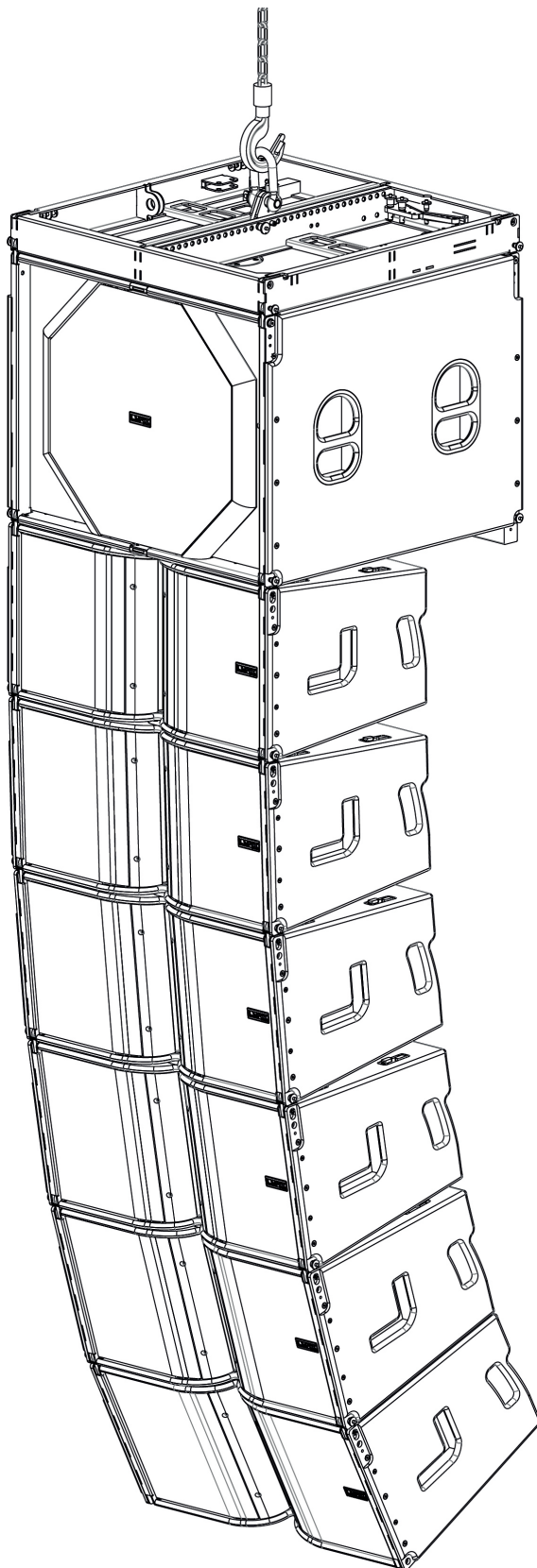

CLS-121S FLOWN CONFIGURATION

- Take the SV-CLS20 flying frame accessory with the levers rise up and place it carefully below the subwoofer CLS-121S. Then make sure to fit in all the screws correctly on the levers until the flying frame is attached to the CLS-121S cabinet.

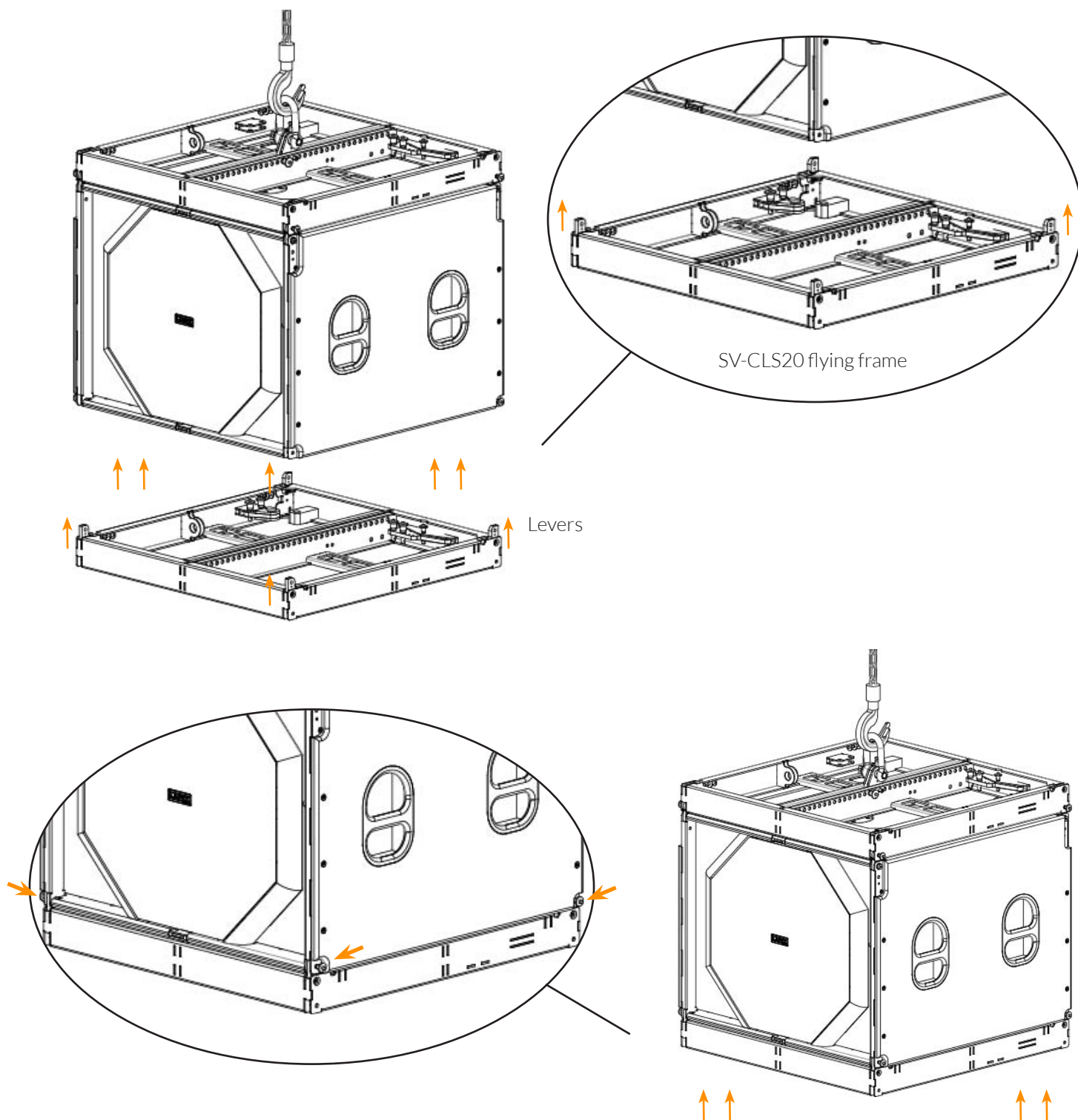

NOTE: Ensure all screws are inserted correctly and fully in their corresponding holes.

CLS-121S FLOWN CONFIGURATION

- Place 4 CLS-212 cabinets with the levers rise up below the CLS-121S subwoofer. Make sure to fit in all the screws correctly on the levers until the array is attached to the CLS-121S cabinet.

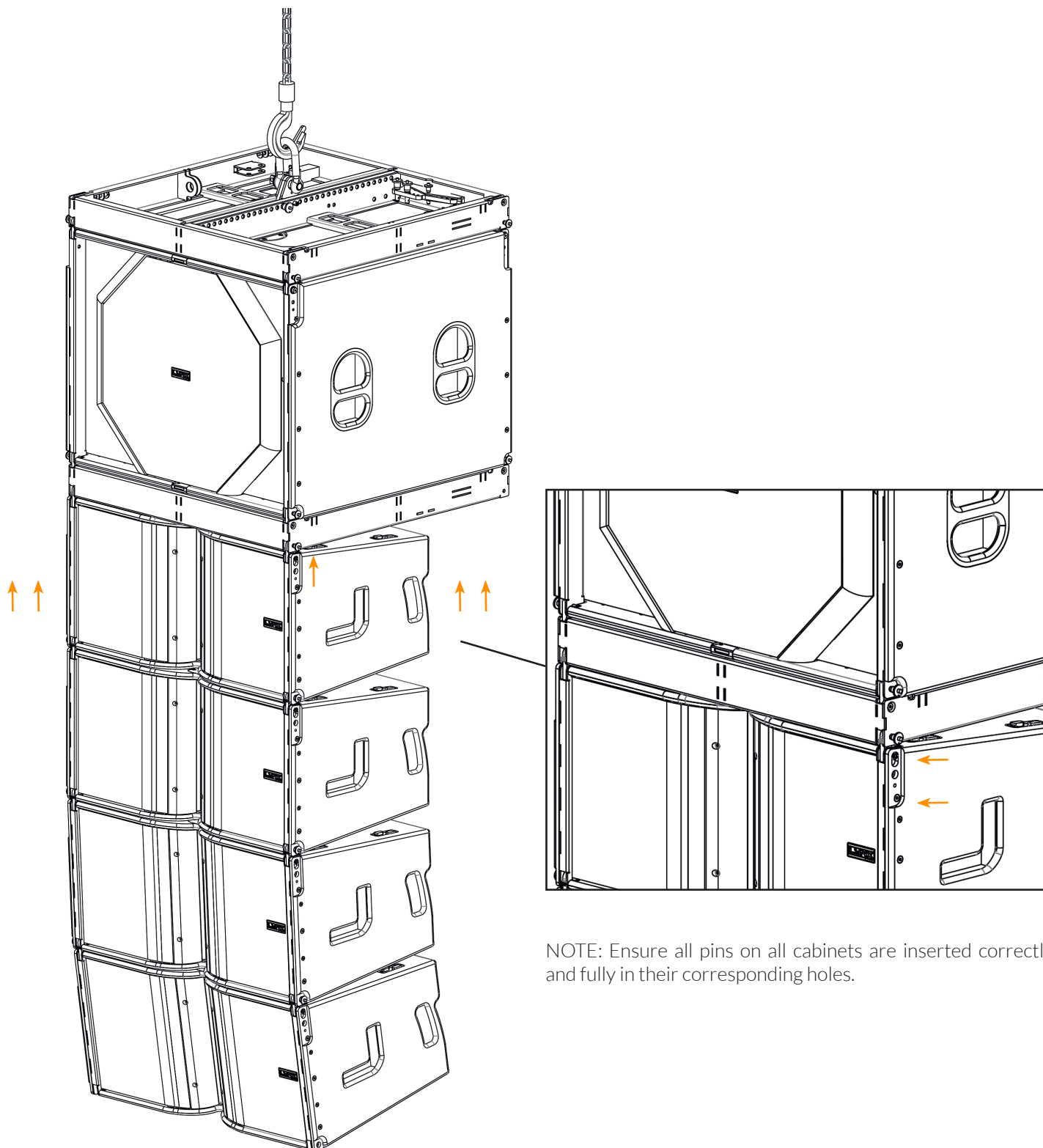

NOTE: Ensure all pins on all cabinets are inserted correctly and fully in their corresponding holes.

CLS-121S STACK CONFIGURATION

- Place 3 CLS-121S subwoofers on top of each other. Be sure to place all screws properly into the levers until the cabinets are tight and the stack configuration is fully secured.

Then place the SV-CLS20 on top of the CLS-121S cabinet for stack configuration. Make sure the CLS-121S subwoofer levers are raised in order to fit the screws between the lever and the flying frame holes.

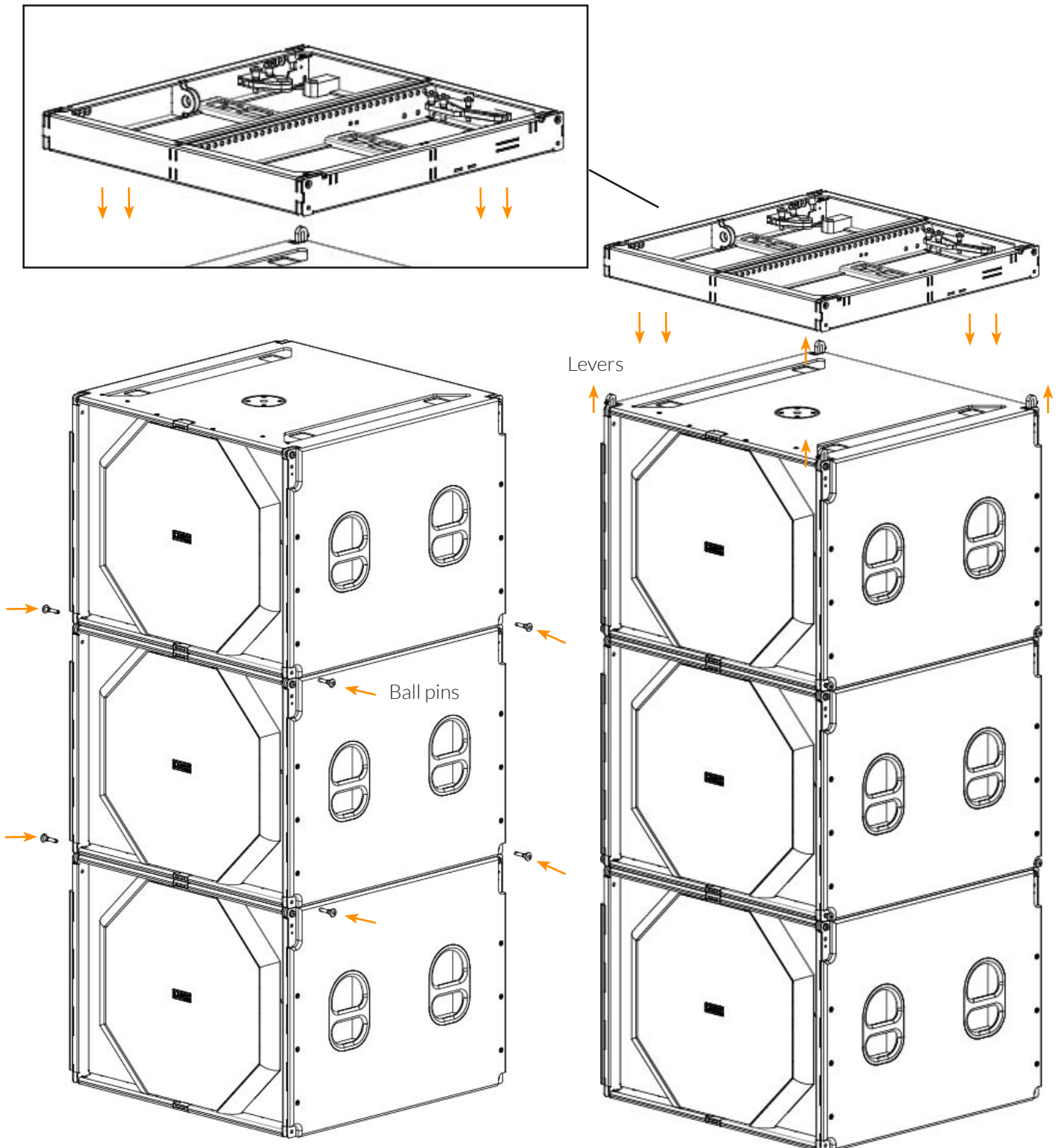

CLS-121S STACK CONFIGURATION

- Once the SV-CLS20 flying frame is placed on top of the CLS-121S make sure that the 4 pins between levers and holes are tight and secured. Also, be sure to remove the pin above the flying frame so that you can attach the CLS-212 cabinet after securing it.

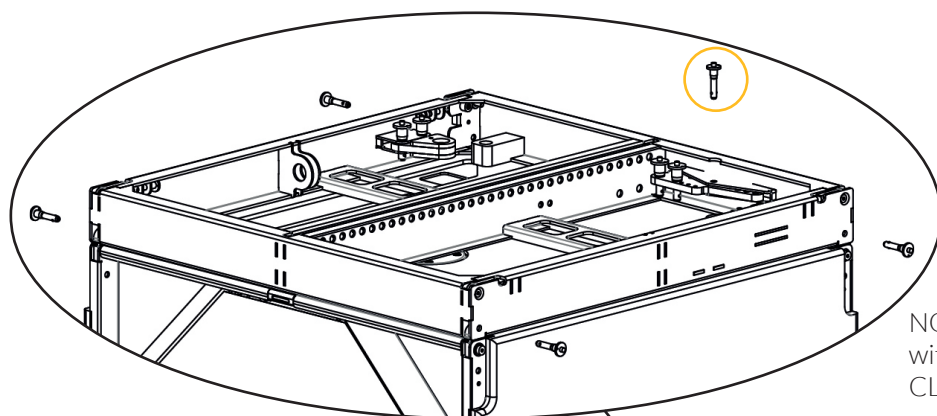

NOTE: Be sure to take out the pin marked with a circle. This is needed to attach the CLS-212 cabinet afterwards.

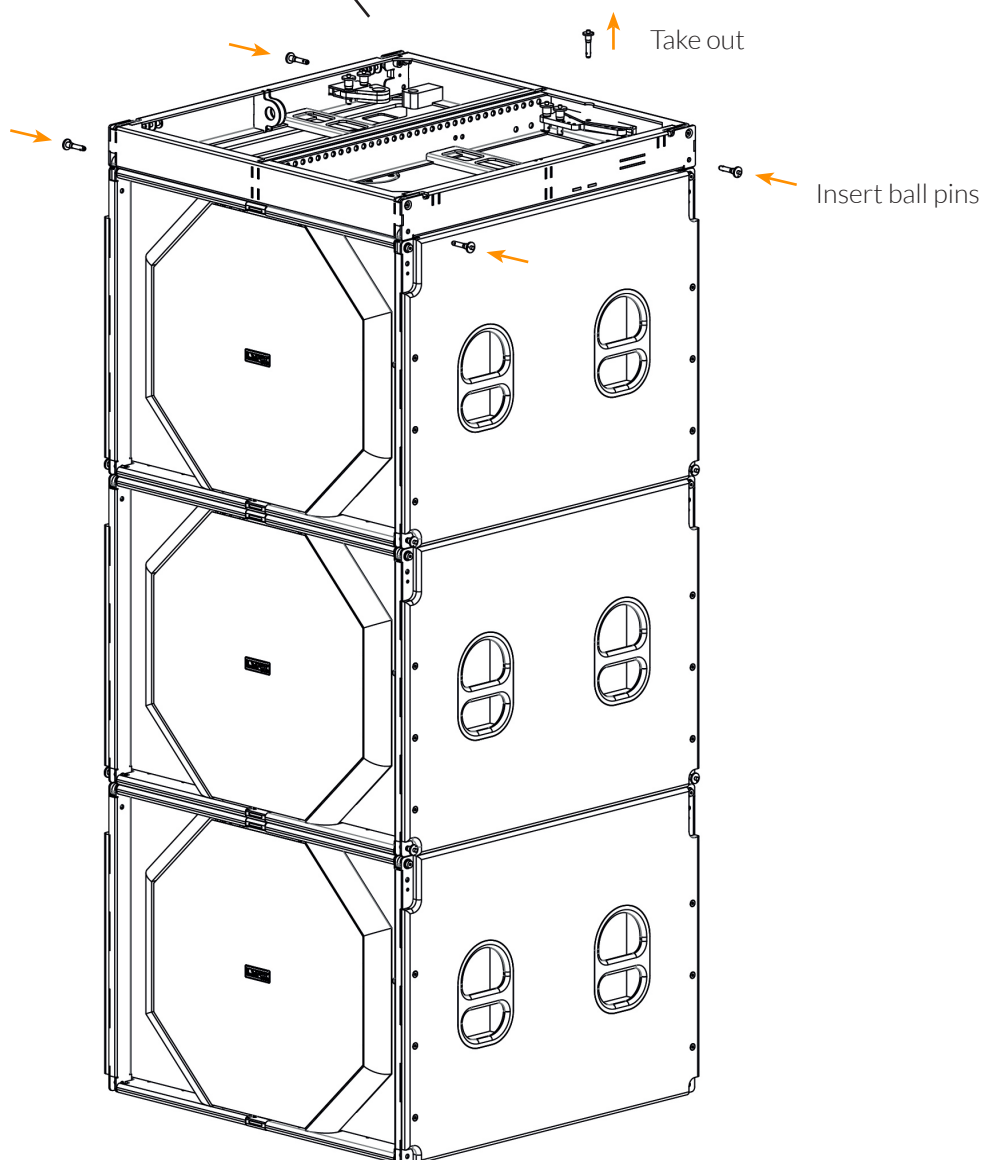

CLS-121S STACK CONFIGURATION

- Once the SV-CLS20 is secured on top of the subwoofer, rise the front levers and the stack adapter. Then secure the stack adapter with pins on both sides.

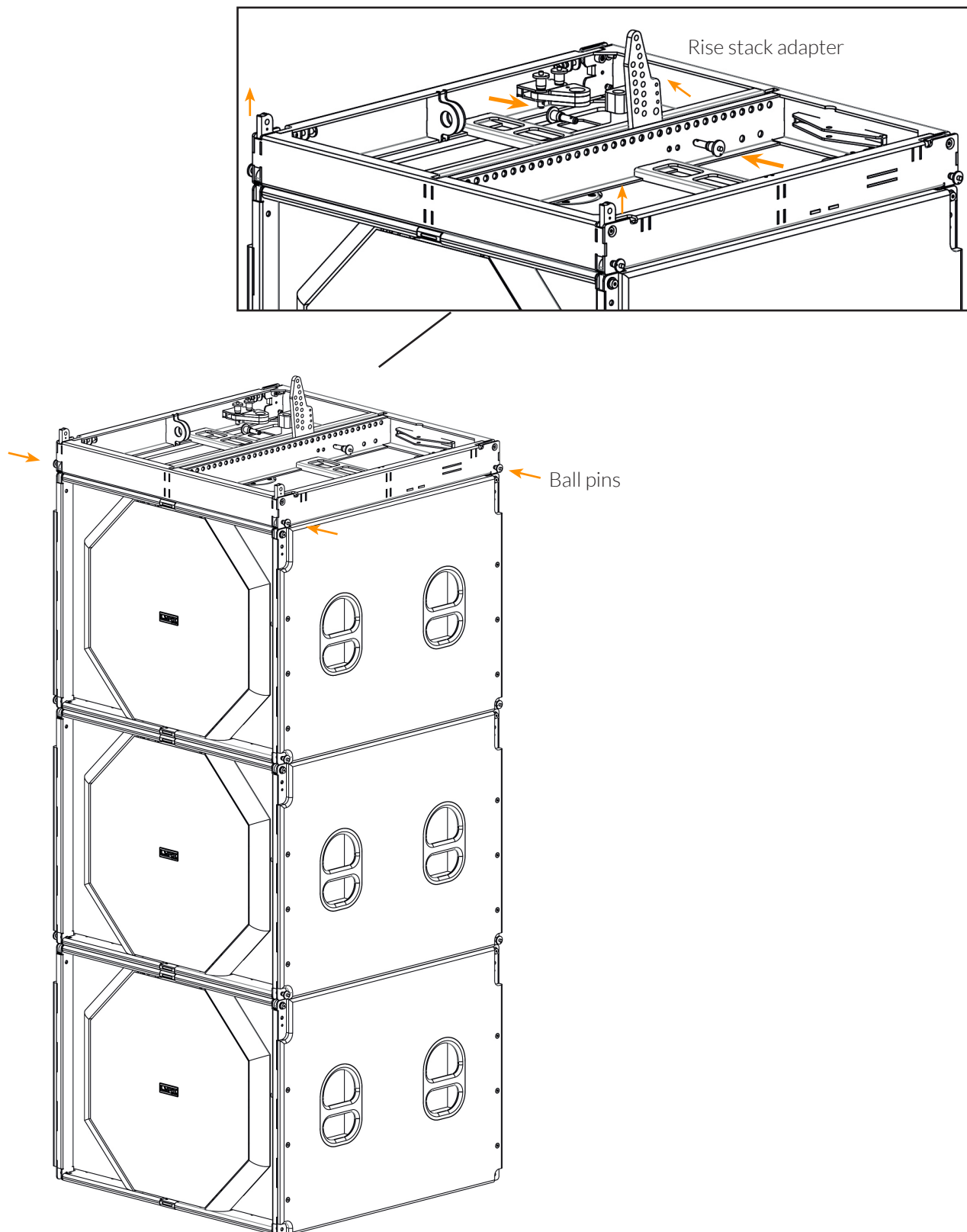

CLS-121S STACK CONFIGURATION

• Place the CLS-212 cabinet carefully on top of the flying frame. Insert the ball pins in the front holes. Then, place the stack adapter between the CLS-212's angle splay. Raise the 3 rigging points (front levers and rear point) to enable an easy set-up.

Reminder: The system can be rigged and angled in retracted position enabling a much easier set-up without the need to lift each cabinet individually.

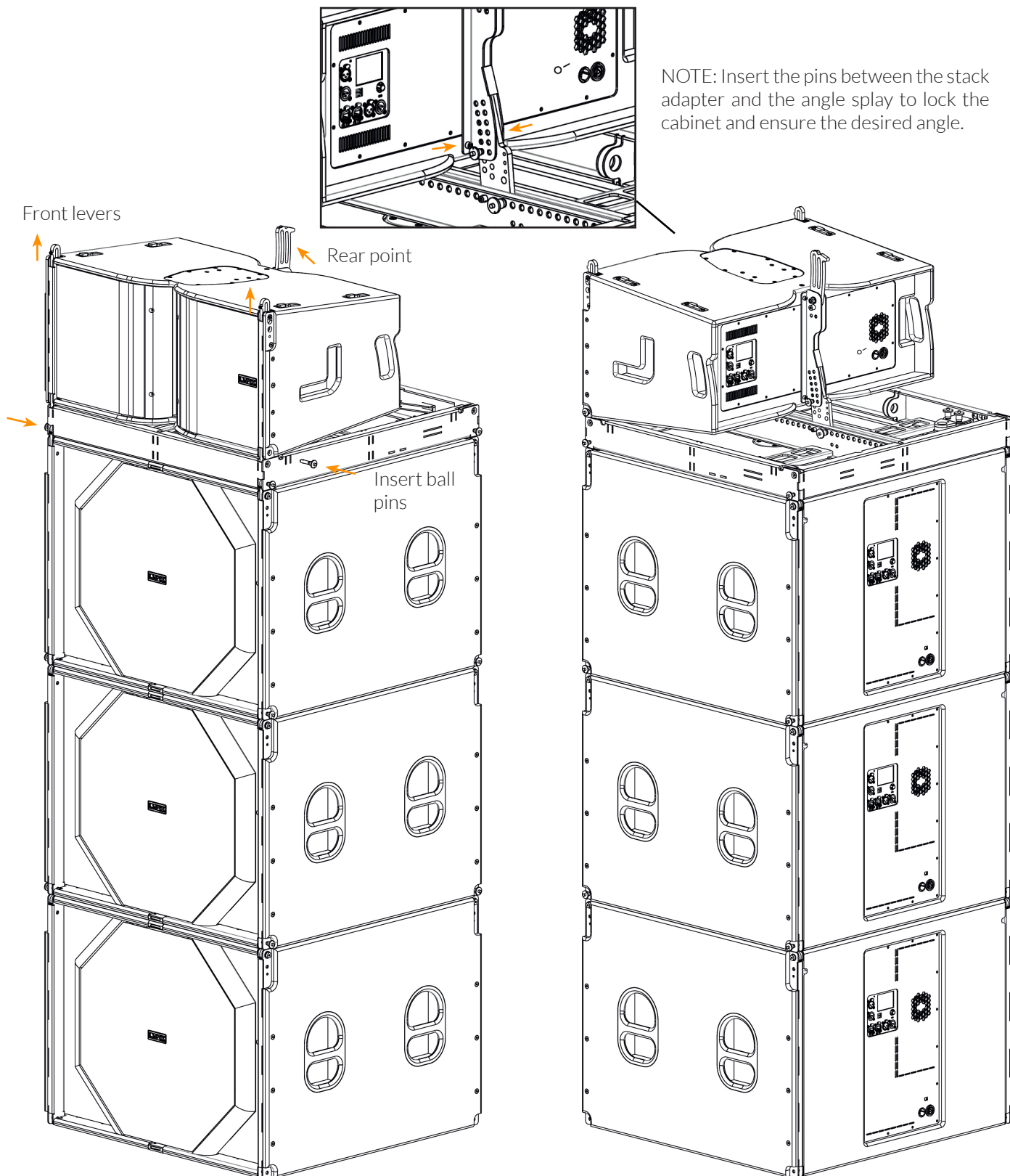

CLS-121S STACK CONFIGURATION

- For stack configuration you can place 3 CLS-212 cabinets on top of CLS-121S subwoofers. Repeat the previous process: introduce the pins on their corresponding holes, assuring that the cabinets are secured through the front levers and the rear rigging point.

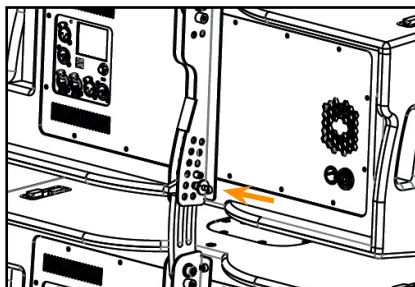

Make sure to fit the pins on the angle splay to get the desired angulation on each cabinet. Our angle splay system allows to create an angulation between 0° to 10° with 1° step increments.

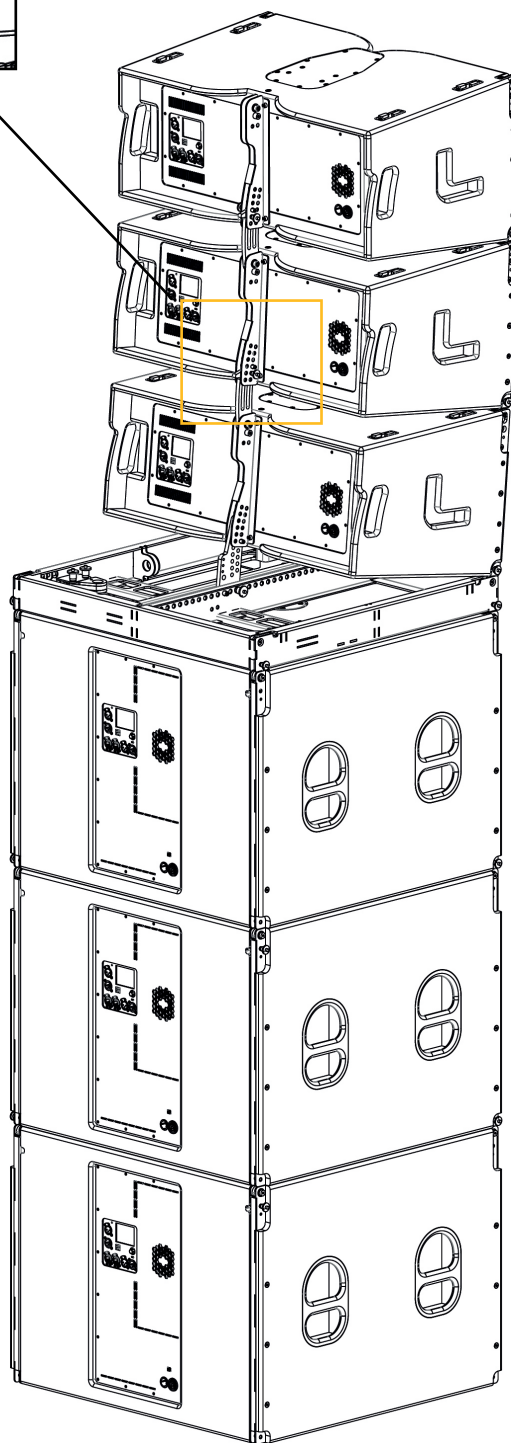
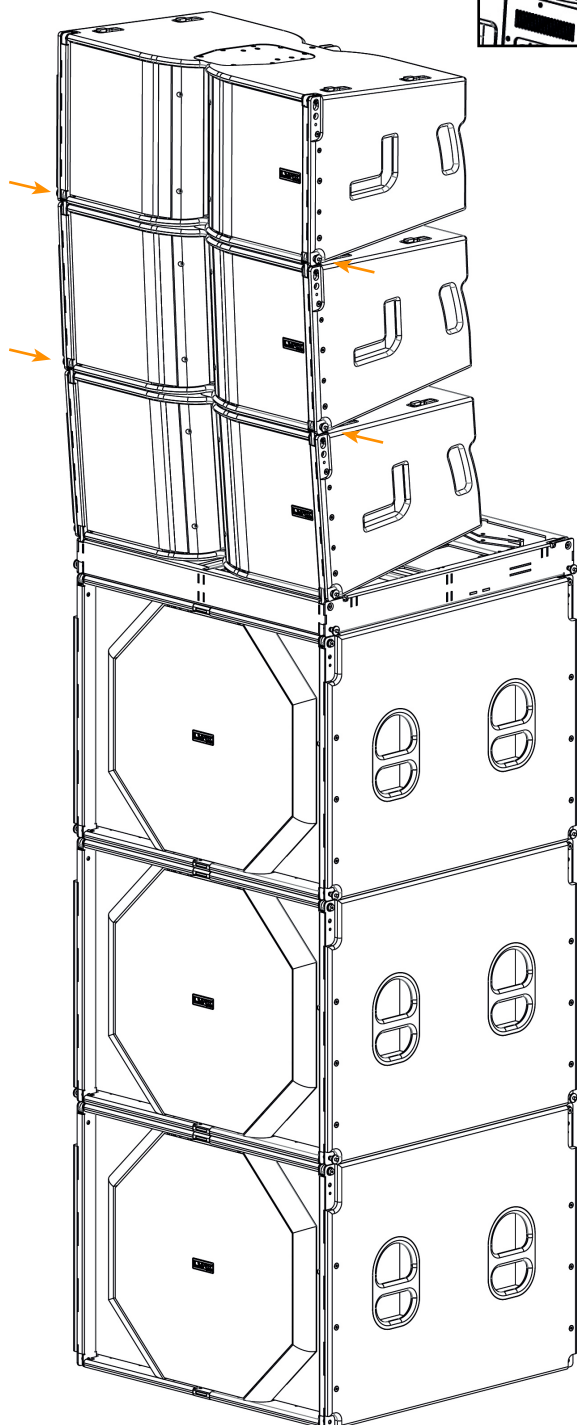

CLS-121S APPLICATIONS

- 3 CLS-121S on a dolly

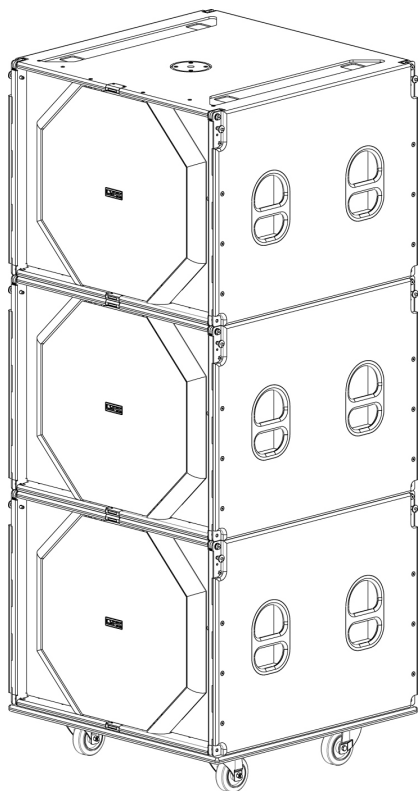

- 3 CLS-121S in cardioid configuration

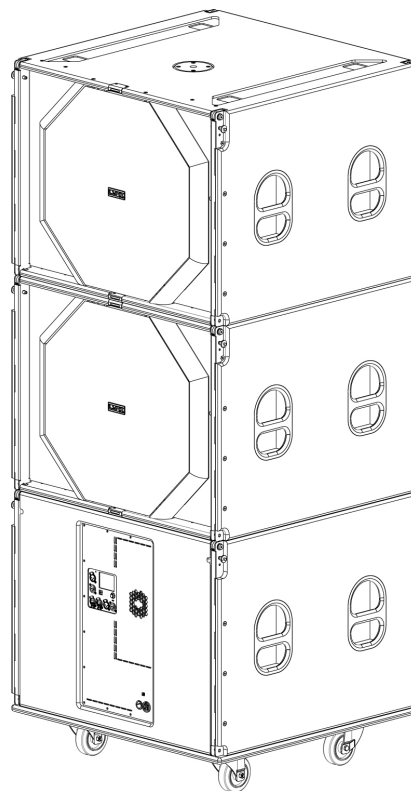

- 2 CLS-121S in cardioid configuration on a dolly

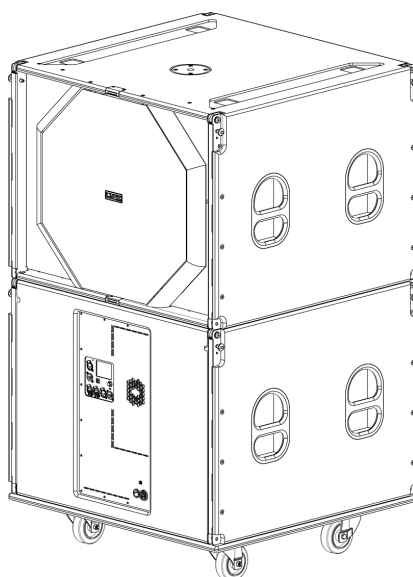

CLS-218S APPLICATIONS

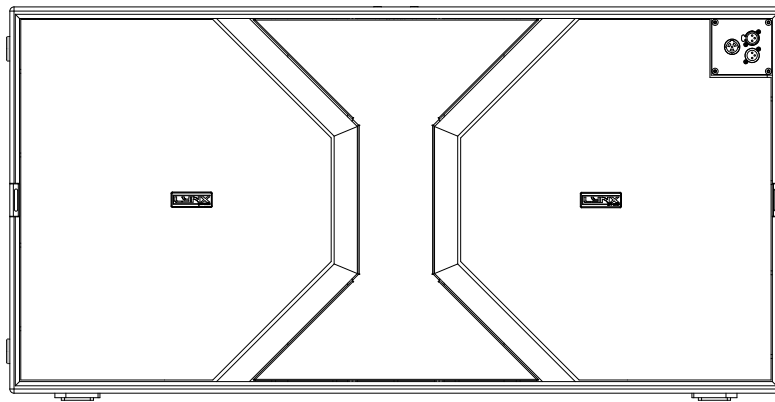

Front connect panel
Anal audio in / thru

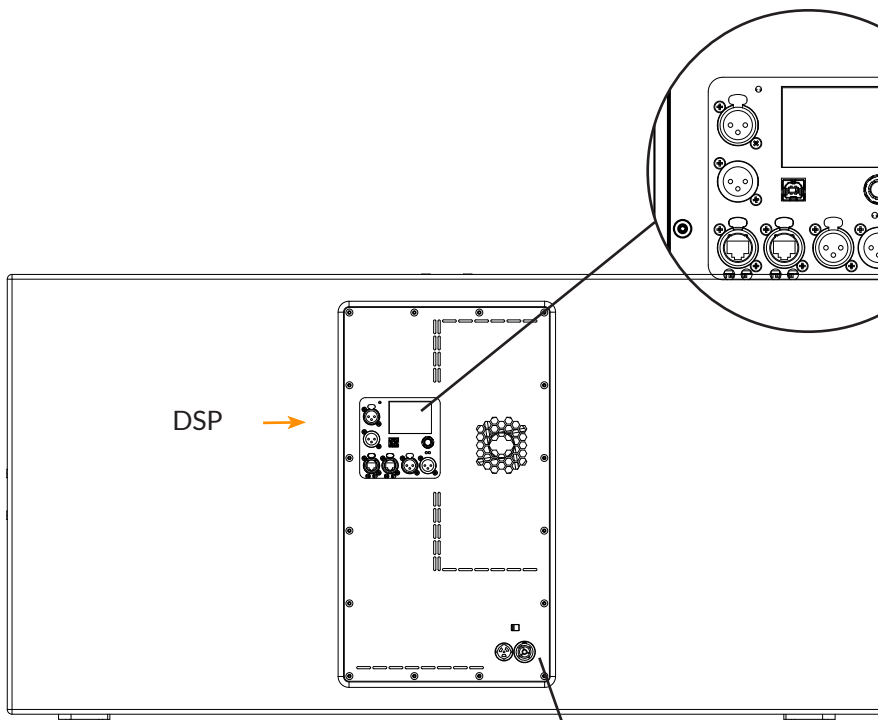
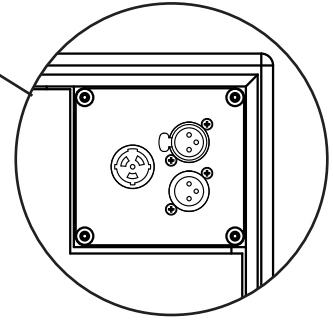

- Screen
- Analog in/thru
- AES/EBU in/thru
- Multifunction joystick
- Ethernet

DSP →

↑
Custom anti-vibration rubber feet

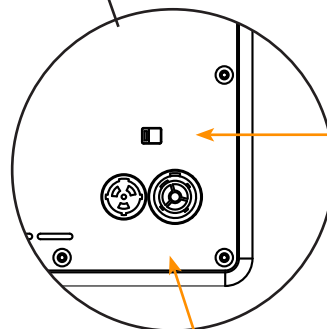

Front/back main select:
"Caution do not change the
position under load"

AC

CLS-218S APPLICATIONS

- Operation modes: Horizontal + Vertical

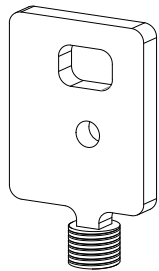
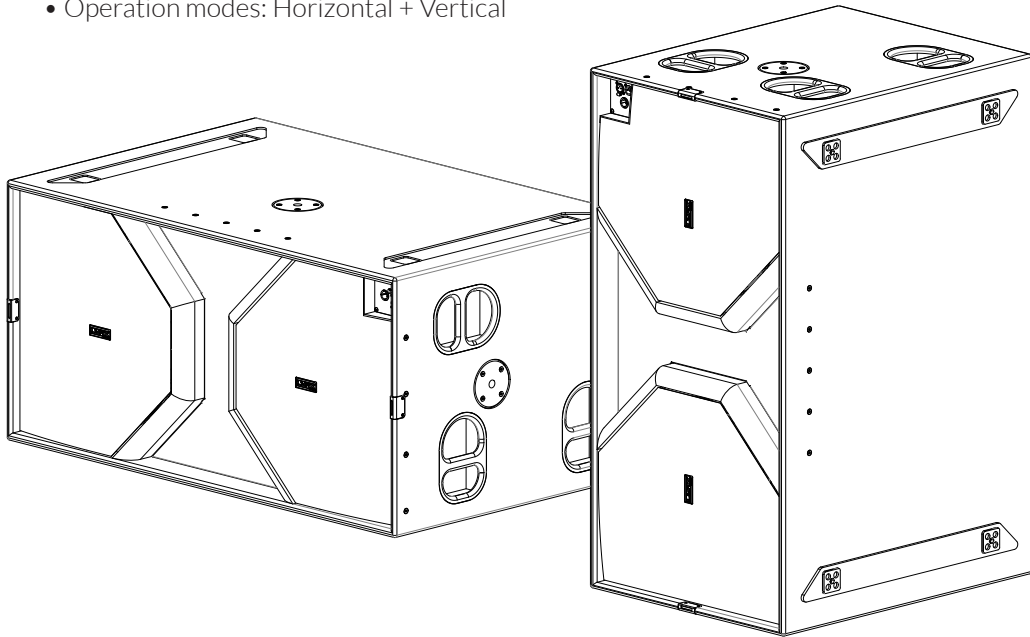

- ST-SVCLS/M20: Kit to connect SV-CLS10 or SV-CLS20 flying frame and M20 plate

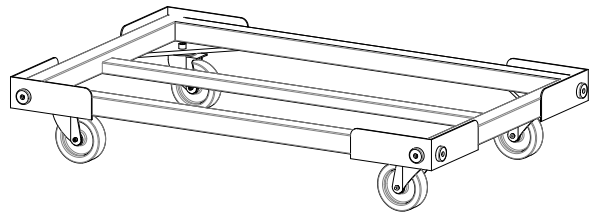

- CA-CLS218S/2: Dolly for CLS-218S with 120mm heavy duty wheels and rubber protection

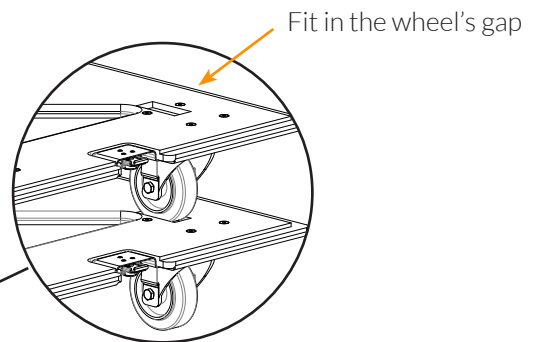
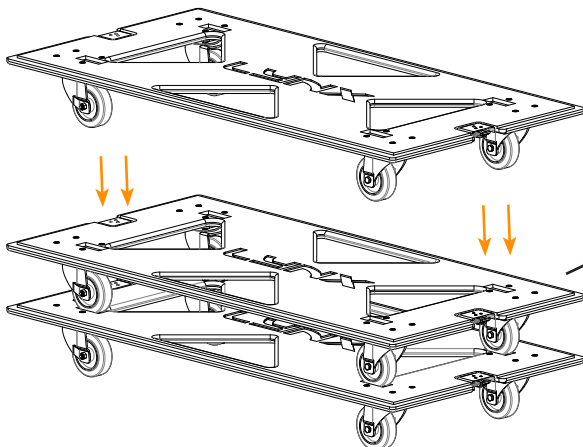

- CA-CLS218S: Removable front transport dolly for CLS-218S. Make sure to fit in the wheel's gap to stack it correctly.

CLS-218S APPLICATIONS

- CLS-218S on a dolly with squid wheels for easy transport.

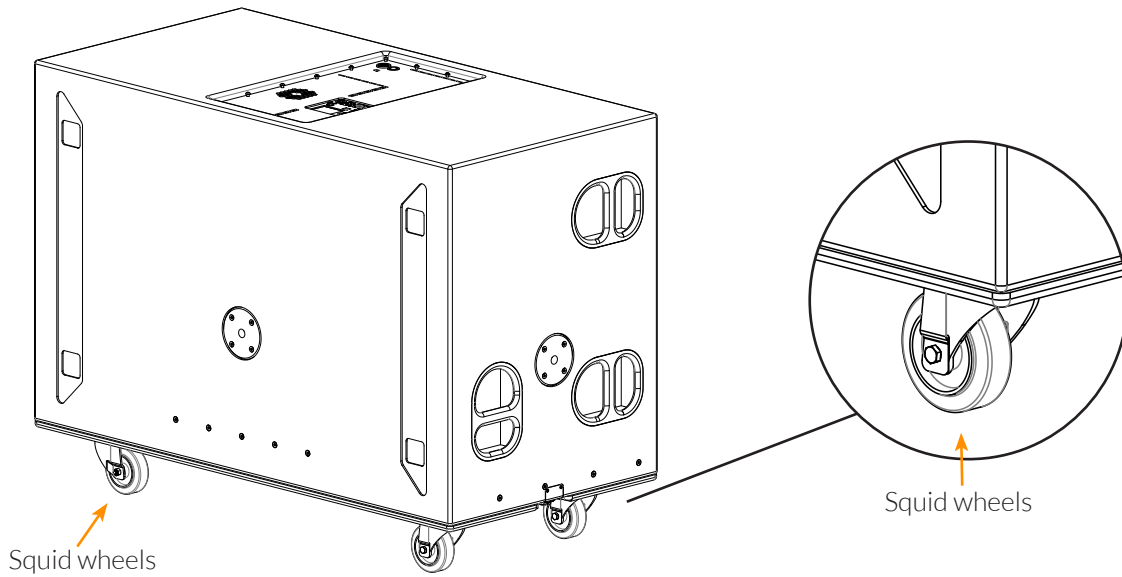

- Lay the cabinet carefully, remove latches and take off the dolly.

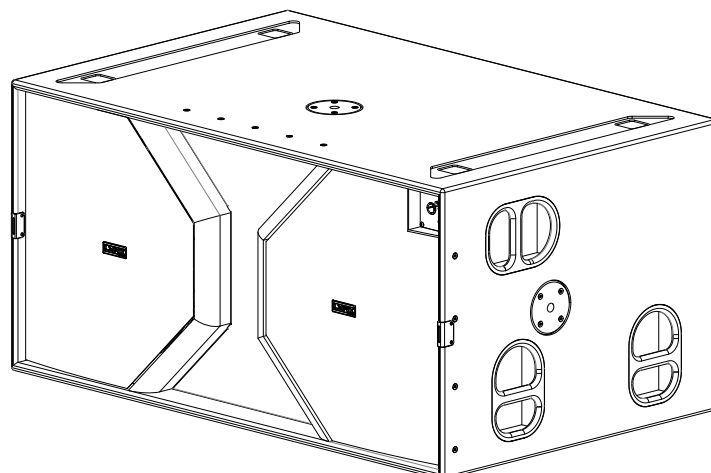
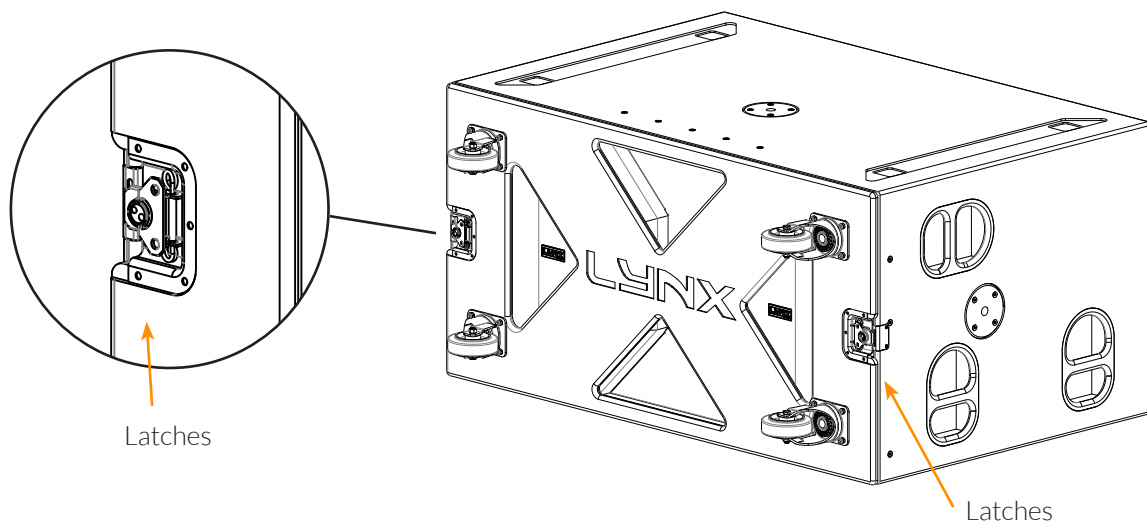

CLS-218S APPLICATIONS

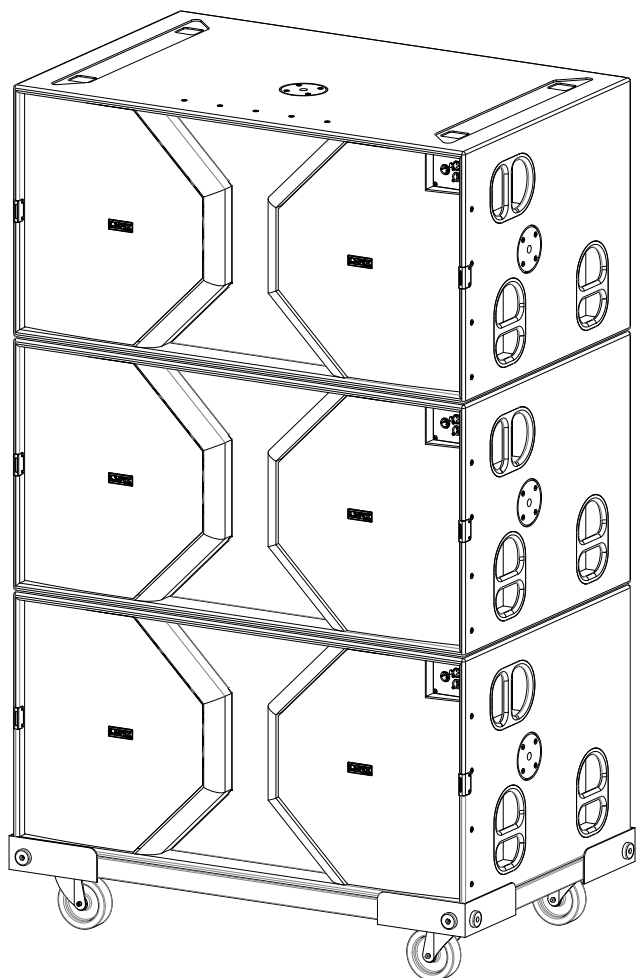

- Up to 3 CLS-218S on a dolly

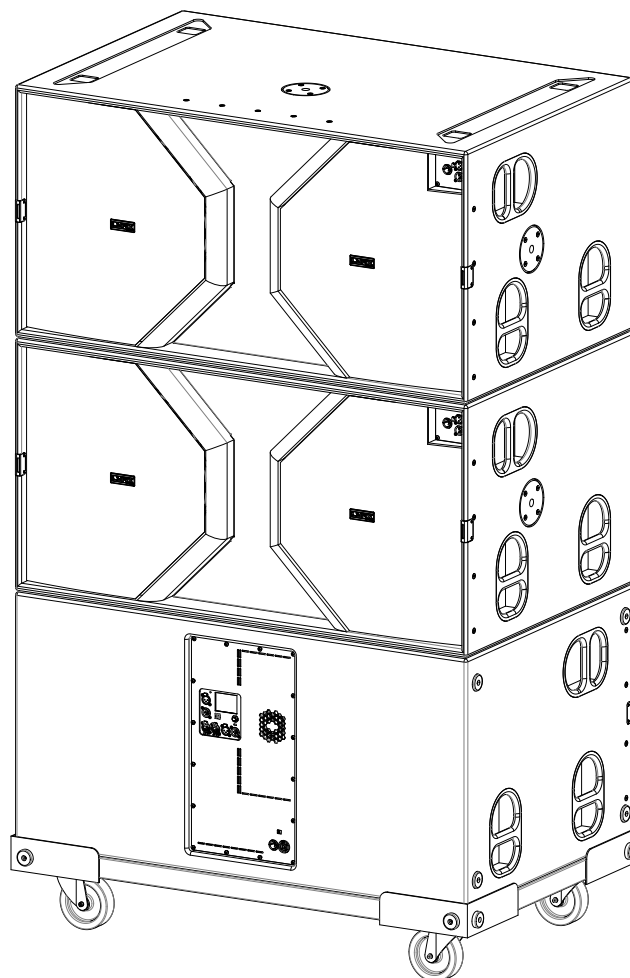

- Up to 3 CLS-218S in cardioid configuration

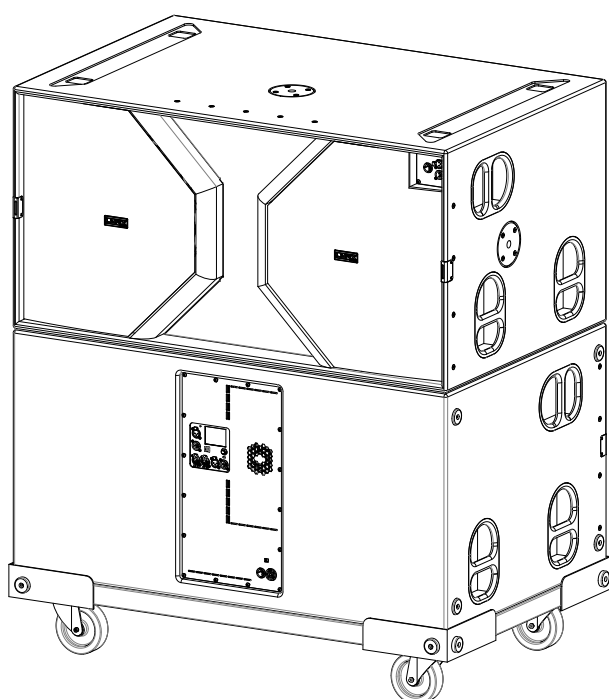

- Up to 2 CLS-218S in cardioid configuration



DECLARATION OF CONFORMITY

Lynx Pro Audio S.L.
Calle 1 - Pol. Ind. Picassent
46220 Picassent (Valencia)
SPAIN - EU
Tel.: (+34) 961 10 96 01
www.lynxproaudio.com

Lynx Pro Audio S.L. declares that CLS series are in conformity with the following EC directives:

Low Voltage Directive	2014/35/UE
Electromagnetic Compatibility EMC	2014/30/UE
RoHS Directive	2011/65/UE
RAEE (WEEE)	2012/19/UE

In accordance with Harmonized European Norms:

EN 60065:2014	Audio, video and similar electronic apparatus. Safety requirements
EN 55032:2012	Electromagnetic compatibility of multimedia equipment. Emission requirements.
EN 55103-2:2009	Electromagnetic compatibility. Product family standard for audio, video, audiovisual and entertainment lighting control apparatus for professional use. Part 2: Immunity.
EN 50581:2012	Technical documentation for the assessment of electrical and electronic products with respect to the restriction of hazardous substances

CLS models: CLS-28 / CLS-212 / CLS-118S / CLS-121S / CLS-218S



LYNX PRO AUDIO GUARANTEE

Lynx products are guaranteed against every kind of manufacturing fault 2 year after the date of sale. When products are under guarantee, the repairing and the free supplying of the device parts in order to correct any kind of defect are guaranteed by Lynx Pro Audio S.L. In the case that the product could not be returned to the factory for checking and repairing, Lynx Pro Audio S.L. would supply all the necessary parts.

Lynx Pro Audio S.L. is not responsible for any damage or defect caused during the transport or caused by an undue or improper handling by a non-authorized person during the life of this guarantee.

All our products undergo rigorous tests and quality controls. We guarantee the characteristics described here within and their quality against any fabrication defect.

The user loses all warranty rights if he incorporates or carries out any modification to the product, if he uses it outside of the stated safe working loads or does not secure the system properly using all the pins in their corresponding holes.

For any question regarding the product, the user must quote the model and serial number.

WEEE Declaration: Electrical and electronic equipment must be disposed of separately from normal waste at the end of its operational lifetime. Please dispose of this product according to the respective national regulations or contractual agreements. If there are any further questions concerning the disposal of this product please contact Lynx Pro Audio S.L.