

# ADP series

## USER MANUAL

ADP-212M

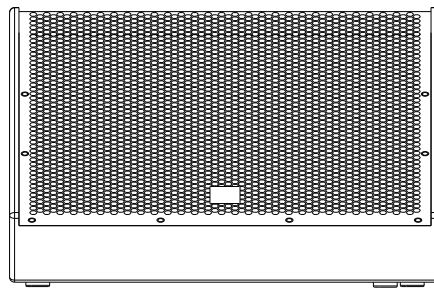

Lynx Pro Audio S.L.



ADP-212M

Manufacturer



LYNX Pro Audio S.L.  
Calle 1 - Pol. Ind. Picassent  
E-46220 Picassent (Valencia)



**CE CERTIFICATION, EUROPEAN PRODUCT**

## INTRODUCTION

The versatile ADP-212M is part of the ADP Self powered, DSP integrated Series. It has been designed to offer the utmost sound reinforcement reliability, incorporating the latest acoustical and electrical technology and delivering incredible, dynamic sound.

The ADP-212M Stage monitor is part of the ADP Self powered, DSP (with FIR Filters) integrated Series. It has been designed to offer the utmost sound reinforcement reliability, incorporating the latest acoustical and electrical technology and delivering incredible, dynamic sound.

Two-way stage monitor providing exceptional performance. Each cabinet has a DSP integrated for system protection and optimization. Other features include temperature sensor, fan speed control, Ethernet options and many more.

Weight and performance are two important considerations when choosing a monitor. The ADP-212M has an unbeatable power to size ratio, there is no need for external amplification racks, is very light weight and as such is the ideal solution for portable or fixed sound reinforcement enabling quick and easy set-ups.

To facilitate, correct and reliable use of the powered cabinet ADP-26 we have designed this instruction manual. Please read the manual carefully before proceeding to install the system.

Please observe the technical data carefully and do not ignore the instructions included within this manual.

## CONTENTS

• SAFETY PRECAUTIONS	4
• SYSTEM OVERVIEW	
ADP-212M	5
BACK PANEL	6
ACCESSORIES	6
• CONNECTORS AND CONNECTIONS	6
CONNECTION EXAMPLE	7
• CONFIGURING THE DIGITAL SIGNAL PROCESSOR	
CONFIGURING THE DSP OPTIONS	8
CONFIGURATION PANEL	9
SELECT AND RUN PRESET	9
• ONLINE CONTROL SYSTEM	10
• RAINBOW 3D ACOUSTIC SIMULATION SOFTWARE	11
• CERTIFICATIONS AND GUARANTEE	12

Before starting to use this device, please read this instruction manual carefully.  
Keep these instructions in the place where the equipment will be used and with easy access to them.



**• Electrical appliance**

The exclamation mark within a triangle identifies the presence of electricity. Use the system carefully without wet hands or feet. Avoid installing the speaker in wet or excessively humid places. Do not place material that contains liquid on or near the unit. Avoid dripping or splashing water or any liquid over the unit. Regularly check the condition of the cables and make sure these are not being walked on or pinched. Connect the speaker to bipolar, earthed mains. The mains plug must be connected to the appropriate protection (fuse or breaker). Connection to any other type of mains could result in an electrical shock and violate local electrical codes.

CAUTION: DO NOT CONNECT OR DISCONNECT THE AC POWER CONNECTORS UNDER LOAD.



**• Heavy equipment**

Apply back protection when using the system. Avoid loading and unloading at heights.



**• Electrical shock risk**

The diagonal mark within a triangle identifies the presence of dangerous voltage.

Do not open or handle the interior of the box. These parts are not to be adjusted by the user. For maintenance and/or repair please go to an authorized service centre. In order to reduce the risk of electric shock, disconnect from AC before plug in or unplugging Audio signal cables. Reconnect to AC only if all signal connections are made and secured. Never manipulate the ground type plug provided.

The AC mains plugs should always remain accessible for operation.

Unplug the loudspeaker during storms or when it's being used for a long time.



**• Hearing damage risk**

These systems can reproduce large quantities of sound pressure which can damage hearing. Take precautions if you are going to be near them for extended amounts of time and do not get too close.



**• Hanging / Flying**

Do not hang the cabinets from the handles or from any other part other than the designated hanging point. When flying this system please observe the technical and "Rainbow" software data carefully. Never exceed the maximum safe working loads or ignore the instructions included within this manual. Use Only flying accessories provided by Lynx Pro Audio S.L. Rigging must be always carried out by professionals.



**• Delicate Material**

Please ensure no foreign object or water enters the speaker. Only clean the unit with dry cloths. Do not use solvents.



**• Overheating / Fire risk**

To reduce the risk of the speaker over heating, avoid direct contact with sunlight. Avoid placing the unit close to heat inducing objects such as radiators. Do not cover the equipment in use and do not block any ventilation openings. Do not put naked flame, such as lighted candles, close or on top of the unit.



**• Electromagnetic and interferente emissions**

Avoid placing objects which through electromagnetic waves can damage the unit, such as mobile phones, lap tops, magnetic strip cards etc.

This system complies with normatives

EN 55103-1 (1)

EN 55103-2 (2)

(1) This device may not cause harmful interferences.

(2) This device may receive interference including interferences that may cause undesired working.



**• IMPORTANT NOTE**

This Equipment must be used in accordance with these instructions and by trained professional personnel only. This equipment should not be used in places with extreme tropical climates. Don't expose this apparatus to extreme humidity and or temperature values.

## SYSTEM OVERVIEW

- **ADP-212M**

High output, self powered (class D switch mode power supply) with PFC (Power Factor Correction), two-way stage monitor.

Consists of two 12" transducers with aluminium voice coil and a compression driver with 1.4" titanium diaphragm with 55° conic dispersion.

DSP (FIR technology) controlled with 2250W amplification, 139dB SPL.

- **Technical Data:**

Components:

- HF 1.4" titanium diaphragm HF driver
- LF/MF 2x12"

Frequency range: 55 Hz – 20 KHz (-10dB)

Frequency response: 60 Hz – 18 KHz (± 3dB)

Max SPL / Peak: 136 dB / 139 dB peak

Coverage angle: 55° H x 55° V

Power amplifier: 2250W Class D

LF/MF amplifier: 1 x 1500 W

HF amplifier: 1 x 750 W

Processing: 56 bit Lynx DSPB-22 with FIR filters

Cabinet adjustment: Back panel LCD

Control connections: XLR / Ethernet (OCS) optional, USB (DSP programming)

AC power: 85V / 270V selectable. 50/60 Hz 3A

AC connections: 16A Neutrik powerCon with link output

Finish: Polyurea coating high grade resistant paint

Material: 15 mm Premium birch plywood

Dimensions: 445 x 688 x 655 mm (H x W x D)

Weight: 42 kg (92 lbs)

- **ADP-212M measurements**

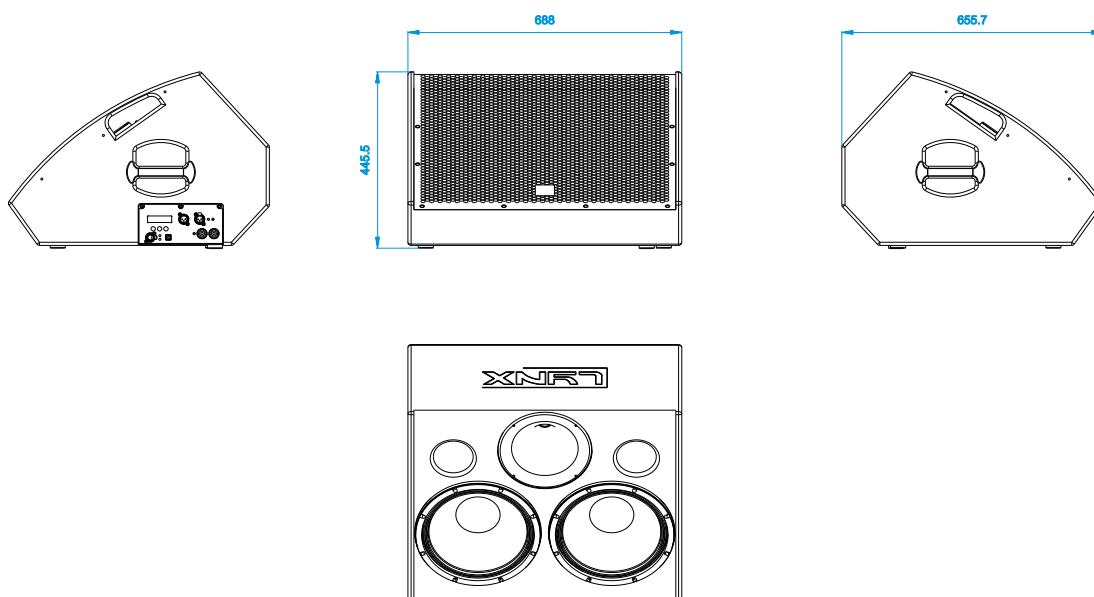

• ADP-212M back panel

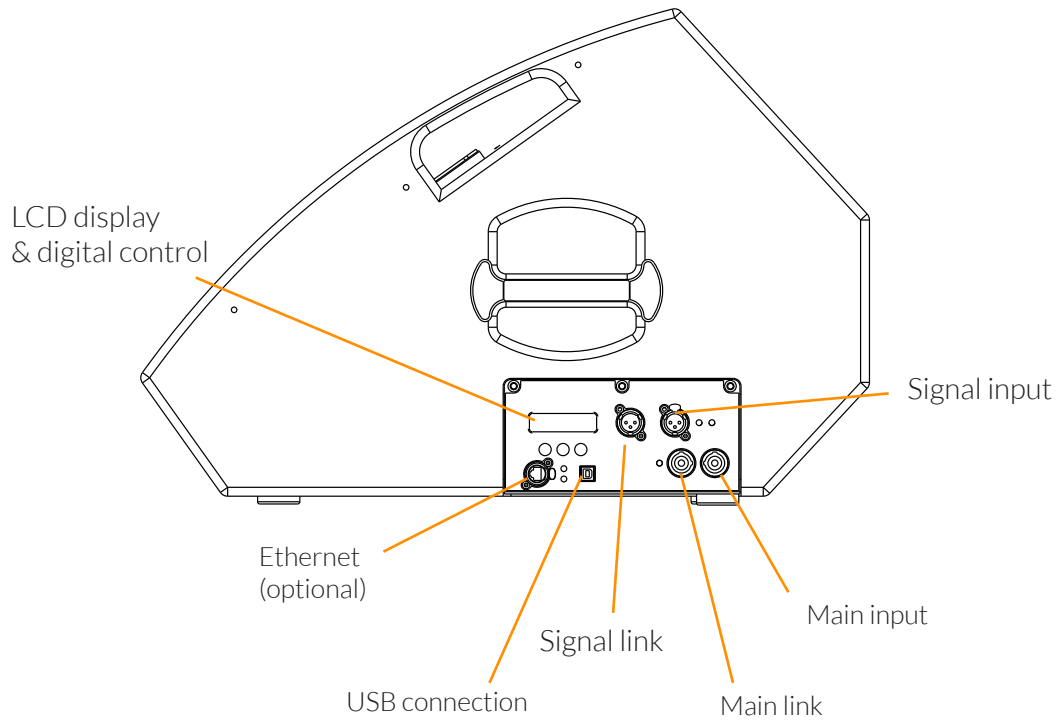

• ADP-212M accessories



FC-212M

Flight case to transport one stage monitor ADP-212M

**CONNECTORS AND CONNECTIONS**

SOCKET POWERCON CONNECTORS



CAUTION: Do not connect or disconnect the AC Power connectors under load.



L - Line  
N - Neutral  
⏏ - Earth

**CONNECTORS AND CONNECTIONS**

**XLR SOCKET CONNECTORS**

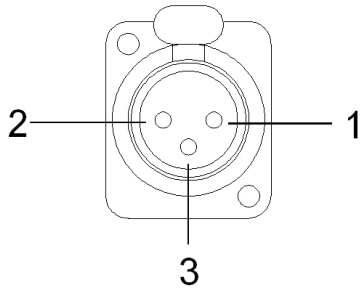

**INPUTS**  
1.- EARTH  
2.- LIVE (+)  
3.- LIVE (-)

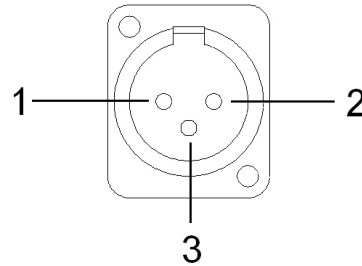

**OUTPUTS**  
1.- EARTH  
2.- LIVE (+)  
3.- LIVE (-)

**XLR AERIAL CONNECTORS**

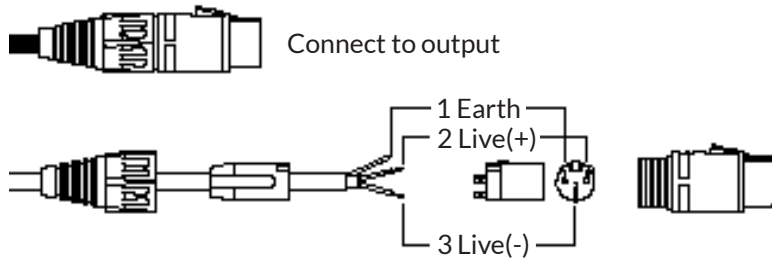
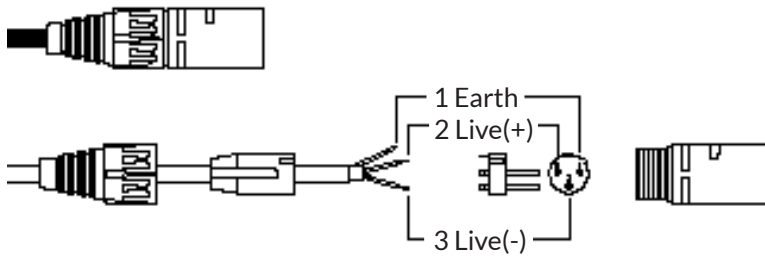

Connect to output

• CONNECTION EXAMPLE: 3 ADP-212M cabinets

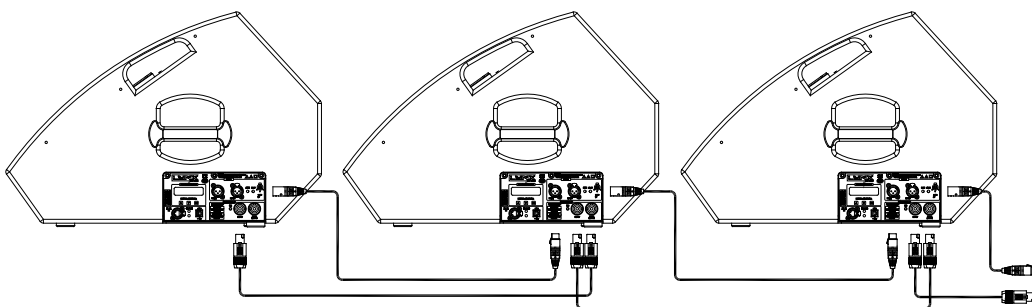

Connect to signal output  
Connect to AC output

**CAUTION:**

Do not connect or disconnect the AC power connectors underload.

## CONFIGURING THE DIGITAL SIGNAL PROCESSOR

From the buttons below the display on the cabinet's back panel you are able to configure the Basic adjustment functions of the internal DSP. Depending on the model, you can find the following configurations:

Preset	Display Name	Additional info
01	FIR FULL RANGE	Full range with FIR filters
02	FIR LPF 16KHz	16 KHz low pass with FIR filters
03	FIR LPF 17KHz	17 KHz low pass with FIR filters
04	FIR HPF 60Hz	60 Hz high pass with FIR filters
05	FIR HP60LP16K	60 Hz high pass 16KHz low pass, FIR filters
06	FIR HP60LP17K	60 Hz high pass 17KHz low pass, FIR filters
07	FIR HPF 80Hz	80 Hz high pass with FIR filters
08	FIR HP80LP16K	80 Hz high pass 16KHz low pass, FIR filters
09	FIR HP80LP17K	80 Hz high pass 17KHz low pass, FIR filters
10	FIR HPF 90Hz	90 Hz high pass with FIR filters
11	FIR HP90LP16K	90 Hz high pass 16KHz low pass, FIR filters
12	FIR HP90LP17K	90 Hz high pass 17KHz low pass, FIR filters
13	FIR HPF 100Hz	100 Hz high pass
14	FIR HP100LP16K	100 Hz high pass 16KHz low pass, FIR filters
15	FIR HP100LP17K	100 Hz high pass 17KHz low pass, FIR filters
16	FIR FULL RANGE	Full range with FIR filters
17	FIR FULL RANGE	Full range with FIR filters
18	FIR FULL RANGE	Full range with FIR filters
19	FIR FULL RANGE	Full range with FIR filters
20	FIR FULL RANGE	Full range with FIR filters

Note:

You must apply the desired configuration in each one cabinet. This is done via the buttons located on the back panel of the cabinet and requires electrical power to work.

### FIR FILTERS

Finite Impulse Response (FIR) filters are used in the signal processing of the ADP-215 cabinet. FIR is a type of digital filter with linear phase characteristics. This frees system designers from the constraints of phase anomalies associated with analogue filters or their digital versions (IIR, Infinite Impulse Response). When properly used, FIR filtering can audibly improve a system's impulse response and reduce crossover interference.



## CONFIGURATION PANEL

On the back panel you will see 3 buttons and an information screen, on which you can read the established parameters and information such as amplification module temperature, input signal level and name of the current preset (Fig1).

If changes are not made the display will automatically dim to save energy and avoid unnecessary light in situations where light is not wanted. To re-activate the light simply press the OK button.



Fig 1

## SELECT THE INPUT: DIGITAL OR ANALOG

To change the preset configuration just press the up button (Fig2(1)) and down button (Fig2(2)) until you see the title and preset number required.

Once found, press OK (Fig2(3)) until the progress bar finishes (Fig3). The display will indicate "Loading DSP" (Fig4).



Fig 2 1 2 3



Fig 3



Fig 4

Note:

In case of a power cut, the DSP will save its last configurations when restarted.

## ONLINE CONTROL SYSTEM

- Who is it for?

Users of Self powered DSP incorporated Lynx Pro Audio Cabinets where the user has requested the cabinets be supplied with the Ethernet Module kit.

- What is it for?

Obtain detailed information of cabinet behaviour and monitor the cabinet/s in real time. You can change the preset, gain, mute, polarity and phase. You can also activate the air absorption compensation and select the «SOLO» mode.

- How does it work?

Via Ethernet (cable or wireless). Once installed, the O.C.S. software automatically detects all the cabinets connected to the network and displays them in the O.C.S. window on the users PC.

- What does it show?

As well as displaying the cabinet model and IP address the O.C.S will be monitoring in real time and the user will be able to view RMS levels, Input clip, power module temperature, compression levels, air absorption compensation and cabinet angulation.

The screenshot displays the OCS Online Control System interface. At the top, it shows the title 'OCS - Online Control System - Project1.prjocs [My Project]'. Below this is a menu bar with options like 'Project', 'Control Groups', and 'Smaart Link'. A toolbar contains various control buttons such as 'Reset Memories', 'Open Memories', 'Save Memories As...', 'Update Speaker Lib', 'Show Frequency Response', 'Real Time Process', 'Lock Buttons', and 'Mode'. The main area is divided into several sections:

- Devices List:** A table on the left lists cabinets with columns for 'Zone / Model', 'Name', and 'Interface'. It shows multiple 'CLS28' cabinets with various IP addresses.
- Control Panels:** Eight individual control panels for 'CLS28 - NoName' units are displayed in a grid. Each panel includes:
  - Power and DSP status (STB ON/OFF, ON/OFF).
  - Tilt and Roll angle settings (e.g., Tilt 5,4°, Roll -2,4°).
  - Input and Output level meters for IN, LF, and MHF channels.
  - Gain settings for each channel (e.g., -40dB).
  - Temperature (T) and Z-axis (Z) indicators.
  - Preset selection (e.g., 'SINGLE ARRAY UNIT').
- Current Preset:** A dropdown menu at the bottom right shows the current preset 'SINGLE ARRAY UNIT' and a list of other available presets like 'STACK WITH CLS-118S', 'FILL APPLICATION', and 'FILL APPLICATION 100Hz'.
- Metadata:** A table at the bottom left provides details for the selected cabinet:
 

Brand	Lynx Pro Audio
Model	CLS28
Name	NoName
Interface	192.168.1.81
Serial Number	19/210/0021
FW Version	1.4.3
Options	STBY / Z / ACCEL

## RAINBOW 3D Acoustic Prediction Software

Lynx Pro Audio's R&D department is working on Rainbow 3D, a new acoustic simulation software with dynamic 3D features. With a sophisticated design, Rainbow 3D stands out for its speed, being able to provide a simulation in just a few seconds. It also provides algorithms for beam steering and optimizing the listening area.

- **Designed from scratch by professionals**

Rainbow 3D has been programmed from scratch by Lynx Pro Audio engineers, using new programming procedures that achieve an effective simulation with really low calculation time.

- **Multiple listening zones**

The program can simulate all Lynx Pro Audio's acoustic enclosures located in a 3D space, including the classic side, top and front views. It can also define multiple listening zones and allows offset positioning and symmetry. Blueprint images, textures and PNG format pictures can be imported.

- **Unlimited sound sources**

Allows the acoustic simulation for an unlimited number of sound sources and audio systems. You can place as many systems (subwoofers, line arrays, columns and individual boxes) as you desire. Also, the line arrays can be placed in stack or flown configuration.

- **Beam steering**

Rainbow 3D has the ability to add DSP processing to the simulation and uses algorithms to control the directivity (beam steering) in columns, without the need to tilt them physically, being able to divide the column into several beams that point to different zones.

- **Accurate optimization thanks to FIR filters**

Optimized algorithms are used in the listening area to improve the sound coverage and the frequency response. This feature can be executed in a matter of seconds. Additionally, the export of FIR coefficients can be performed with the optimization for later loading in the DSP via Ethernet or a USB device. In the near future direct communication with Lynx Pro Audio and OCS will be available.

- **Multiple measures and tools**

Likewise, the R&D department is developing multiple measurement and analysis tools for the calculated data. For example, the sound pressure curves (SPL) in the listening areas and the capture of virtual measurements that show the frequency response in the points of location indicated and added. Among other tools you will find autoplay and a wizard to set up different subwoofer arrangements.

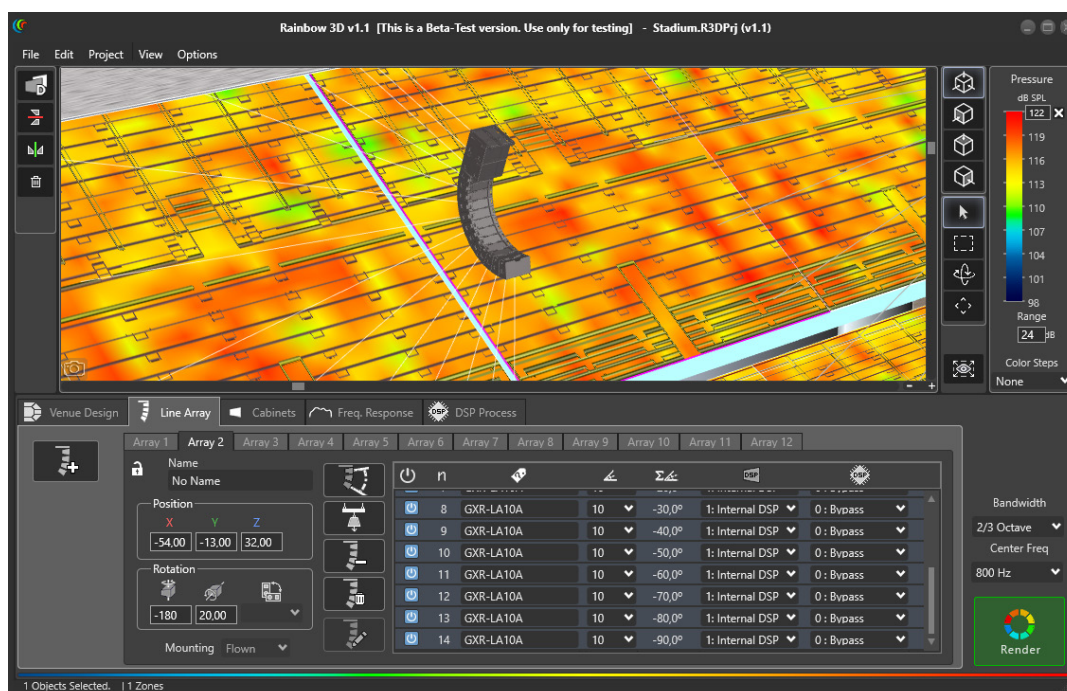



## DECLARATION OF CONFORMITY

**Lynx Pro Audio S.L.**  
Calle 1 - Pol. Ind. Picassent  
46220 Picassent (Valencia)  
SPAIN - EU  
Tel.: (+34) 961 10 96 01  
[www.lynxproaudio.com](http://www.lynxproaudio.com)

Lynx Pro Audio S.L. declares that ionic series are in conformity with the following EC directives:

Low Voltage Directive	2006/95/EC
Electromagnetic Compatibility EMC	2004/108/EC
RoHS Directive	2002/95/EC

In accordance with Harmonized European Norms:

EN 60065:2002	Audio, video and similar electronic apparatus. Safety requirements
EN 55103-1:1996	Electromagnetic compatibility. Product family standard for audio, video, audiovisual and entertainment lighting control apparatus for professional use. Part 1: Emission.
EN 55103-2:1996	Electromagnetic compatibility. Product family standard for audio, video, audiovisual and entertainment lighting control apparatus for professional use. Part 2: Immunity.
ADP models:	ADP-215 / ADP-15 / ADP-12 / ADP-26 / ADP-212M / ADP-12M / ADP-18S / ADP-12S



## LYNX PRO AUDIO GUARANTEE

Lynx products are guaranteed against every kind of manufacturing fault 2 year after the date of sale. When products are under guarantee, the repairing and the free supplying of the device parts in order to correct any kind of defect are guaranteed by Lynx Pro Audio S.L. In the case that the product could not be returned to the factory for checking and repairing, Lynx Pro Audio S.L. would supply all the necessary parts.

Lynx Pro Audio S.L. is not responsible for any damage or defect caused during the transport or caused by an undue or improper handling by a non-authorized person during the life of this guarantee.

All our products undergo rigorous tests and quality controls. We guarantee the characteristics described here within and their quality against any fabrication defect.

The user loses all warranty rights if he incorporates or carries out any modification to the product, if he uses it outside of the stated safe working loads or does not secure the system properly using all the pins in their corresponding holes.

For any question regarding the product, the user must quote the model and serial number.

**WEEE Declaration:** Electrical and electronic equipment must be disposed of separately from normal waste at the end of its operational lifetime. Please dispose of this product according to the respective national regulations or contractual agreements. If there are any further questions concerning the disposal of this product please contact Lynx Pro Audio S.L.